

Grizzly *Industrial, Inc.*®

MODEL T20797 52" FOOT SHEAR OWNER'S MANUAL



COPYRIGHT © OCTOBER, 2008 BY GRIZZLY INDUSTRIAL, INC REVISED FEBRUARY 2009.

**WARNING: NO PORTION OF THIS MANUAL MAY BE REPRODUCED IN ANY SHAPE
OR FORM WITHOUT THE WRITTEN APPROVAL OF GRIZZLY INDUSTRIAL, INC.**

#CR11247 PRINTED IN CHINA

 **WARNING!**

This manual provides critical safety instructions on the proper setup, operation, maintenance and service of this machine/equipment.

Failure to read, understand and follow the instructions given in this manual may result in serious personal injury, including amputation, electrocution or death.

The owner of this machine/equipment is solely responsible for its safe use. This responsibility includes but is not limited to proper installation in a safe environment, personnel training and usage authorization, proper inspection and maintenance, manual availability and comprehension, application of safety devices, blade/cutter integrity, and the usage of personal protective equipment.

The manufacturer will not be held liable for injury or property damage from negligence, improper training, machine modifications or misuse.

 **WARNING!**

Some dust created by power sanding, sawing, grinding, drilling, and other construction activities contains chemicals known to the State of California to cause cancer, birth defects or other reproductive harm. Some examples of these chemicals are:

- **Lead from lead-based paints.**
- **Crystalline silica from bricks, cement and other masonry products.**
- **Arsenic and chromium from chemically-treated lumber.**

Your risk from these exposures varies, depending on how often you do this type of work. To reduce your exposure to these chemicals: Work in a well ventilated area, and work with approved safety equipment, such as those dust masks that are specially designed to filter out microscopic particles.

Table of Contents

- INTRODUCTION..... 2**
 - Manual Accuracy..... 2
 - Contact Info..... 2
 - Functional Overview..... 2
 - Identification..... 3
 - Machine Data Sheet..... 4
- SECTION 1: SAFETY..... 5**
 - Safety Instructions for Machinery..... 5
 - Additional Safety Instructions for Foot Shears..... 7
- SECTION 2: SET UP..... 8**
 - Setup Safety..... 8
 - Items Needed for Set Up..... 8
 - Unpacking..... 8
 - Inventory..... 9
 - Clean Up..... 10
 - Site Considerations..... 10
 - Moving & Placement..... 11
 - Mounting to Shop Floor..... 11
 - Assembly..... 12
- SECTION 3: OPERATIONS..... 14**
 - Operation Safety..... 14
 - Basic Controls..... 14
 - Stops & Guides..... 15
 - Operation Overview..... 15
 - Shearing Tips..... 15
 - Finger Guard..... 15
 - Hold-Down Adjustment..... 16
 - Blade Adjustment..... 16
- SECTION 4: ACCESSORIES..... 18**
- SECTION 5: MAINTENANCE..... 20**
 - Schedule..... 20
 - Unpainted Cast Iron..... 20
 - Lubrication..... 20
- SECTION 6: SERVICE..... 21**
 - Troubleshooting..... 21
 - Blade Sharpening/Replacement..... 21
 - Adjusting Blade Bow..... 22
 - Gib Adjustment..... 22
- SECTION 7: PARTS..... 23**
 - Shear Assembly Breakdown..... 23
 - Table Assembly Breakdown..... 24
 - Labels Breakdown & List..... 26
- WARRANTY AND RETURNS..... 29**

INTRODUCTION

Manual Accuracy

We are proud to offer this manual with your new machine! We've made every effort to be exact with the instructions, specifications, drawings, and photographs of the machine we used when writing this manual. However, sometimes errors do happen and we apologize for them.

Also, owing to our policy of continuous improvement, **your machine may not exactly match the manual**. If you find this to be the case, and the difference between the manual and machine leaves you in doubt, immediately call our technical support for updates or clarification.

For your convenience, we always keep current Grizzly manuals and most updates available on our website at **www.grizzly.com**. Any updates to your machine will be reflected in these documents as soon as they are complete. Visit our site often to check for the latest updates!

Contact Info

We stand behind our machines. If you have any service questions, parts requests or general questions about the machine, please call or write us at the location listed below.

Grizzly Industrial, Inc.
1203 Lycoming Mall Circle
Muncy, PA 17756
Phone: (570) 546-9663
Fax: (800) 438-5901
E-Mail: techsupport@grizzly.com

If you have any comments regarding this manual, please write to us at the address below:

Grizzly Industrial, Inc.
c/o Technical Documentation Manager
P.O. Box 2069
Bellingham, WA 98227-2069
Email: manuals@grizzly.com

Functional Overview

A foot shear is a machine that uses the operator's body weight to cut sheet metal. A stationary blade is mounted to the machine base and a moving blade is connected to a foot lever. These two blades pass by each other, creating a shearing action.

To cut a sheet metal workpiece on the Model T20797, the operator places the workpiece on the machine table, aligning the desired cut line with the shear blades. The operator then presses down on the foot pedal. This action lowers the hold-down, securing the position of the workpiece. As the foot pedal is pressed further down, the upper blade passes through the workpiece, cutting it into two pieces.

For large workpieces, the Model T20797 is equipped with front and rear extension arms. These arms provide additional support for ease of use and safety during operation. In addition to this support, they also provide mounting points for work stops that can be used when creating repetitive cuts. Once positioned, these eliminate the need for measuring and marking the workpiece.



Identification

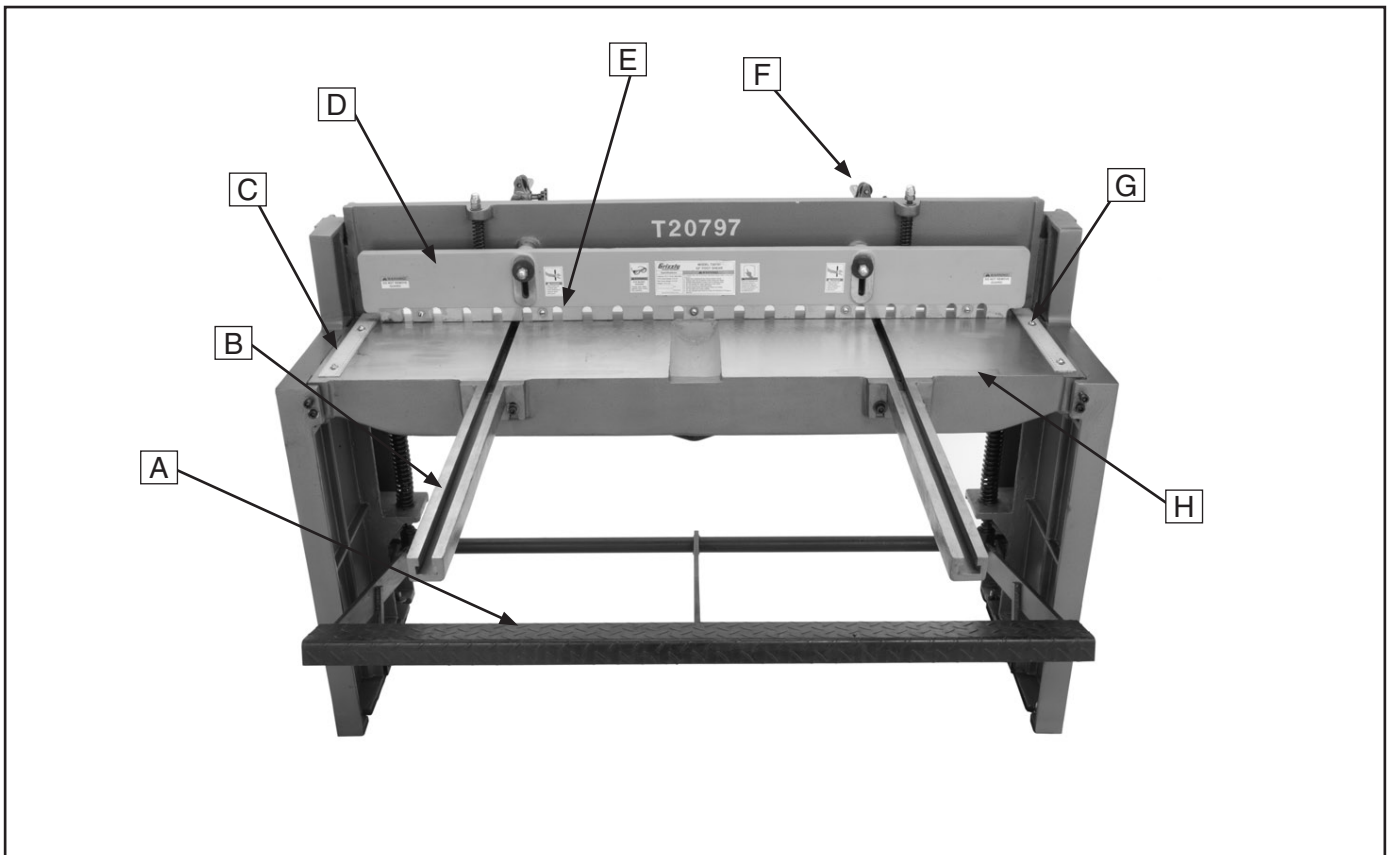

Figure 1. Identification.

- A.** Foot Pedal
- B.** Front Extension Arm
- C.** Scaled Guides
- D.** Hold-down
- E.** Safety Shield
- F.** Rear Extension Arm
- G.** Scale
- H.** Table





MACHINE DATA SHEET

Customer Service #: (570) 546-9663 • To Order Call: (800) 523-4777 • Fax #: (800) 438-5901

MODEL T20797 52" SHEET METAL SHEAR

Design Type Foot Shear / Floor Model

Product Dimensions:

Shipping Dimensions 66" x 39" x 47⁵/₈"
 Shipping Weight 1144 lbs.
 Overall Dimensions (L x W x H) 74" x 62" x 41"
 Weight 1012 lbs.
 Footprint 61³/₄" x 21¹/₂"

Capacities:

Shear 52" @ 18 ga. Mild Steel"
 Front Stop Scale Range 0"-24"
 Rear Stop Scale Range 0"-30"

Construction:

Shear Blades Precision Ground Hardened Steel
 Frame Cast-Iron
 Table Machined Cast-Iron
 Hold-Down Clamp Cast-Iron

Features:

..... Front Stops & Micro-Adjustable Rear Stops
 Front Extension Arms



SECTION 1: SAFETY

WARNING

For Your Own Safety, Read Instruction Manual Before Operating this Machine

The purpose of safety symbols is to attract your attention to possible hazardous conditions. This manual uses a series of symbols and signal words intended to convey the level of importance of the safety messages. The progression of symbols is described below. Remember that safety messages by themselves do not eliminate danger and are not a substitute for proper accident prevention measures.



Indicates an imminently hazardous situation which, if not avoided, **WILL** result in death or serious injury.



Indicates a potentially hazardous situation which, if not avoided, **COULD** result in death or serious injury.



Indicates a potentially hazardous situation which, if not avoided, **MAY** result in minor or moderate injury. It may also be used to alert against unsafe practices.

NOTICE

This symbol is used to alert the user to useful information about proper operation of the machine.

WARNING

Safety Instructions for Machinery

- 1. READ THE ENTIRE MANUAL BEFORE STARTING MACHINERY.** Machinery presents serious injury hazards to untrained users.
- 2. ALWAYS USE ANSI APPROVED SAFETY GLASSES WHEN OPERATING MACHINERY.** Everyday eyeglasses only have impact resistant lenses—they are NOT safety glasses.
- 3. ALWAYS WEAR A NIOSH APPROVED RESPIRATOR WHEN OPERATING MACHINERY THAT PRODUCES DUST.** Most types of dust (wood, metal, etc.) can cause severe respiratory illnesses.
- 4. ALWAYS USE HEARING PROTECTION WHEN OPERATING MACHINERY.** Machinery noise can cause permanent hearing loss.
- 5. WEAR PROPER APPAREL. DO NOT** wear loose clothing, gloves, neckties, rings, or jewelry that can catch in moving parts. Wear protective hair covering to contain long hair and wear non-slip footwear.
- 6. NEVER OPERATE MACHINERY WHEN TIRED OR UNDER THE INFLUENCE OF DRUGS OR ALCOHOL.** Be mentally alert at all times when running machinery.



WARNING

Safety Instructions for Machinery

7. **ONLY ALLOW TRAINED AND PROPERLY SUPERVISED PERSONNEL TO OPERATE MACHINERY.** Make sure operation instructions are safe and clearly understood.
8. **KEEP CHILDREN AND VISITORS AWAY.** Keep all children and visitors a safe distance from the work area.
9. **MAKE WORKSHOP CHILDPROOF.** Use padlocks, master switches, and remove start switch keys.
10. **NEVER LEAVE WHEN MACHINE IS RUNNING.** Turn power **OFF** and allow all moving parts to come to a complete stop before leaving machine unattended.
11. **DO NOT USE IN DANGEROUS ENVIRONMENTS.** DO NOT use machinery in damp, wet locations, or where any flammable or noxious fumes may exist.
12. **KEEP WORK AREA CLEAN AND WELL LIGHTED.** Clutter and dark shadows may cause accidents.
13. **USE A GROUNDED EXTENSION CORD RATED FOR THE MACHINE AMPERAGE.** Grounded cords minimize shock hazards. Undersized cords create excessive heat. Always replace damaged extension cords.
14. **ALWAYS DISCONNECT FROM POWER SOURCE BEFORE SERVICING MACHINERY.** Make sure switch is in OFF position before reconnecting.
15. **MAINTAIN MACHINERY WITH CARE.** Keep blades sharp and clean for best and safest performance. Follow instructions for lubricating and changing accessories.
16. **MAKE SURE GUARDS ARE IN PLACE AND WORK CORRECTLY BEFORE USING MACHINERY.**
17. **REMOVE ADJUSTING KEYS AND WRENCHES.** Make a habit of checking for keys and adjusting wrenches before turning machinery **ON**.
18. **CHECK FOR DAMAGED PARTS BEFORE USING MACHINERY.** Check for binding or misaligned parts, broken parts, loose bolts, and any other conditions that may impair machine operation. Repair or replace damaged parts before operation.
19. **USE RECOMMENDED ACCESSORIES.** Refer to the instruction manual for recommended accessories. Improper accessories increase risk of injury.
20. **DO NOT FORCE MACHINERY.** Work at the speed for which the machine or accessory was designed.
21. **SECURE WORKPIECE.** Use clamps or a vise to hold the workpiece when practical. A secured workpiece protects your hands and frees both hands to operate the machine.
22. **DO NOT OVERREACH.** Maintain stability and balance at all times.
23. **MANY MACHINES CAN EJECT WORKPIECES TOWARD OPERATOR.** Know and avoid conditions that cause the workpiece to "kickback."
24. **ALWAYS LOCK MOBILE BASES (IF USED) BEFORE OPERATING MACHINERY.**
25. **CERTAIN DUST MAY BE HAZARDOUS** to the respiratory systems of people and animals, especially fine dust. Be aware of the type of dust you are exposed to and always wear a respirator designed to filter that type of dust.



WARNING

Additional Safety Instructions for Foot Shears

1. **GUARDS.** Keep all guards in place and in working order.
2. **FOOTING.** Never stand on the foot pedal with both feet. Keep one foot on the ground at all times to maintain your balance. Never jump on the foot pedal to make a cut.
3. **HANDS AND FINGERS.** Always keep hands and fingers away from the blade and hold-down.
4. **OPERATOR POSITION.** Keep all body parts out of the way of all moving parts. Serious pinches and cuts could occur.
5. **CAPACITY.** Never exceed the rated capacity for this foot shear.
6. **PROPER USE.** Only use the foot shear for the purpose it was designed. **DO NOT** cut round stock.
7. **EXTENSION ARMS.** Always be aware of the extension arm location when working around the shear to avoid walking into them, causing injury and damage to the tool.
8. **COMFORTABLE CUTTING OPERATIONS.** Avoid awkward operations and hand positions where a sudden slip could cause your hand or body to fall into a sharp edge or corner.
9. **EXPERIENCING DIFFICULTIES.** If at any time you are experiencing difficulties performing the intended operation, stop using the shear! Contact Tech Support at (570) 546-9663.
10. **BLADE ADJUSTMENTS AND MAINTENANCE.** Always keep blades properly adjusted and sharp.

WARNING

Like all machinery there is potential danger when operating this machine. Accidents are frequently caused by lack of familiarity or failure to pay attention. Use this machine with respect and caution to lessen the possibility of operator injury. If normal safety precautions are overlooked or ignored, serious personal injury may occur.

CAUTION

No list of safety guidelines can be complete. Every shop environment is different. Always consider safety first, as it applies to your individual working conditions. Use this and other machinery with caution and respect. Failure to do so could result in serious personal injury, damage to equipment, or poor work results.



SECTION 2: SET UP

Setup Safety

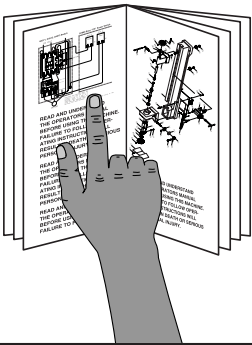

! WARNING
 This machine presents serious injury hazards to untrained users. Read through this entire manual to become familiar with the controls and operations before starting the machine!



! WARNING
 Wear safety glasses during the entire set up process!

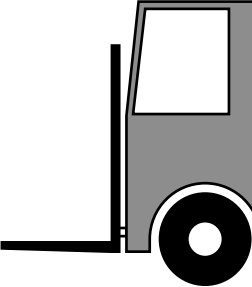

! WARNING
 The Model T20797 is an extremely heavy machine. Serious personal injury may occur if safe moving methods are not followed. To be safe, you will need assistance and power equipment when moving the shipping crate and removing the machine from the crate.

Items Needed for Set Up

The following items are needed to complete the set up process, but are not included with your machine:

Description	Qty
• Forklift or Hoist (1000 lb. min. capacity).....	1
• Lifting Straps (1000 lb. min. capacity)	2
• Safety Glasses (for each person).....	1
• Shop Rags.....	As Needed
• Cleaning Solvent	As Needed
• Standard Feeler Gauge Set	1
• Medium Weight Paper.....	1-2 Sheets
• Helper.....	1
• Wrench 21mm	1
• Wrench 24mm	1
• Stock for Shim 1/8"	1

Unpacking

The Model T20797 was carefully packed when it left our warehouse. If you discover the machine is damaged after you have signed for delivery, *please immediately call Customer Service at (570) 546-9663 for advice.*

Save the containers and all packing materials for possible inspection by the carrier or its agent. *Otherwise, filing a freight claim can be difficult.*

When you are completely satisfied with the condition of your shipment, you should inventory the contents.



Inventory

After all the parts have been removed from the two boxes, you should have the following items:

Box 1: (Figure 2)	Qty
A. Sheet Metal Shear.....	1
B. Rear Stop Assembly.....	1
C. Rear Stop Rods.....	2
D. Front Extension Arms.....	2
E. Extension Arm Guide Assembly	1

In the event that any nonproprietary parts are missing (e.g. a nut or a washer), we would be glad to replace them, or for the sake of expediency, replacements can be obtained at your local hardware store.

NOTICE

Some hardware/fasteners on the inventory list may arrive pre-installed on the machine. Check these locations before assuming that any items from the inventory list are missing.



⚠ WARNING

SUFFOCATION HAZARD!

Immediately discard all plastic bags and packing materials to eliminate choking/suffocation hazards for children and animals.

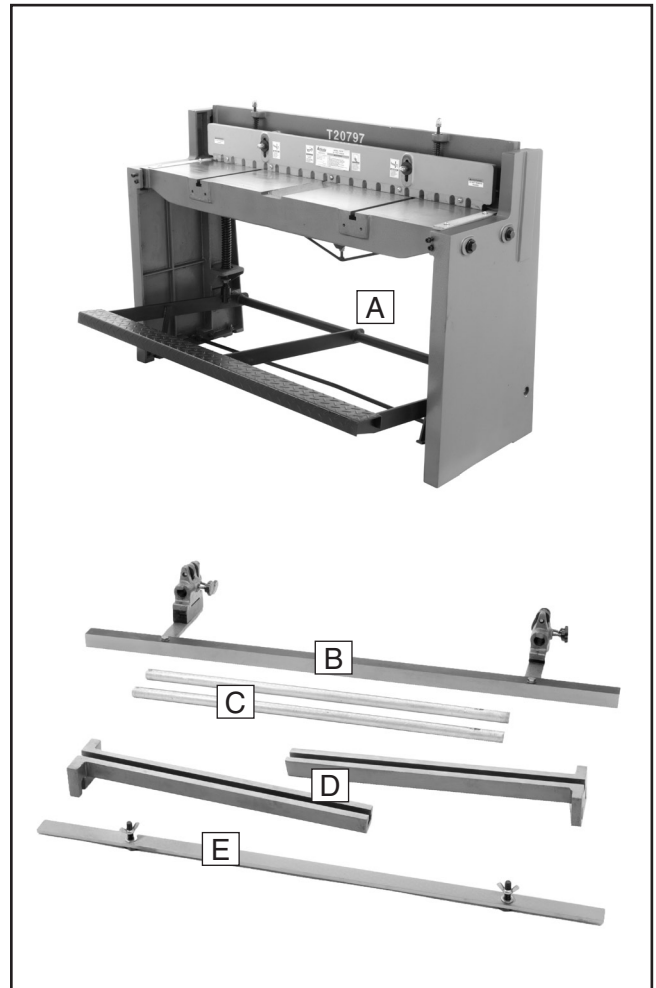



Figure 2. Inventory.



Clean Up

The unpainted surfaces are coated with a waxy oil to prevent corrosion during shipment. Remove this protective coating with a solvent cleaner or degreaser, such as shown in **Figure 3**. For thorough cleaning, some parts must be removed. **For optimum performance, clean all moving parts or sliding contact surfaces.** Avoid chlorine-based solvents, such as acetone or brake parts cleaner that may damage painted surfaces. Always follow the manufacturer's instructions when using any type of cleaning product.

	<p>! WARNING Gasoline and petroleum products have low flash points and can explode or cause fire if used to clean machinery. DO NOT use these products to clean the machinery.</p>
---	--

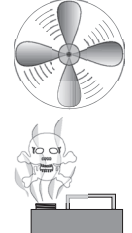
	<p>! CAUTION Many cleaning solvents are toxic if inhaled. Minimize your risk by only using these products in a well ventilated area.</p>
---	---

G2544—Solvent Cleaner & Degreaser
H9692—Orange Power Degreaser
 Great products for removing shipping grease.

<p>Call 1-800-523-4777 To Order</p>	
--	---

Figure 3. Cleaner/degreasers available from Grizzly.

Site Considerations

Floor Load

Refer to the **Machine Data Sheet** for the weight and footprint specifications of your machine. Some residential floors may require additional reinforcement to support both the machine and operator.

Placement Location

Consider existing and anticipated needs, size of material to be processed through each machine, and space for auxiliary stands, work tables or other machinery when establishing a location for your new machine. See **Figure 4** for the minimum working clearances.

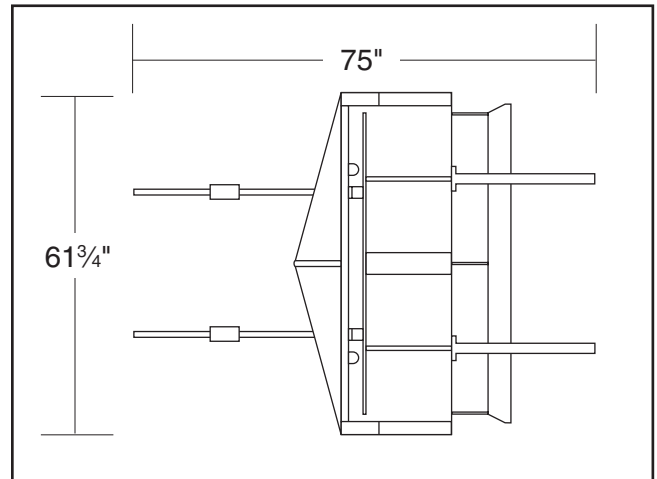
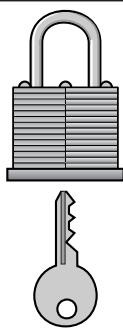

Figure 4. Minimum working clearances.

	<p>! CAUTION Children and visitors may be seriously injured if unsupervised around this machine. Lock entrances to the shop or disable start switch or power connection to prevent unsupervised use.</p>
--	---



Moving & Placement

The Model T20797 is a heavy machine. A forklift or other lifting device will be needed to lift the shear off of the pallet. Place lifting straps under the table and connect them to the forklift forks. Have a helper nearby to assist and stabilize the shear while you lift it, as shown in **Figure 5**.

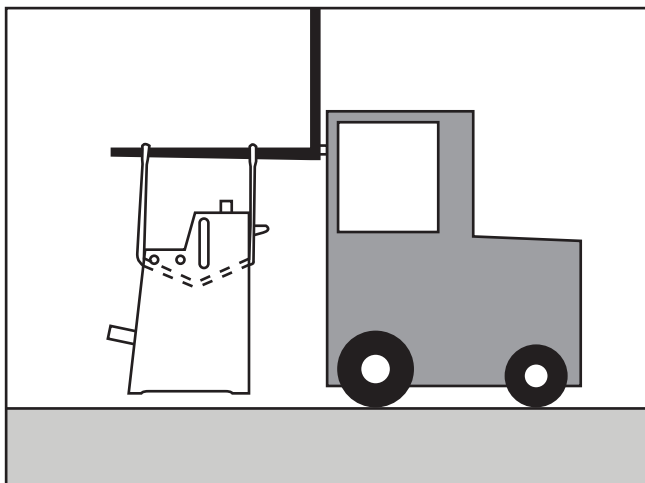

Figure 5. Lifting the foot shear.

Mounting to Shop Floor

The Model T20797 must be mounted to the floor to avoid accidental tipping during use. Because floor materials vary, floor mounting hardware is not included. Whichever option you choose, it is necessary to level your machine with a precision level.

Lag shield anchors with lag bolts and anchor studs (**Figure 6**) are two popular methods for anchoring an object to a concrete floor. We suggest you research the many options and methods for mounting your machine and choose the best that fits your specific application.

NOTICE

Anchor studs are stronger and more permanent alternatives to lag shield anchors; however, they will stick out of the floor, which may cause a tripping hazard if you decide to move your machine.

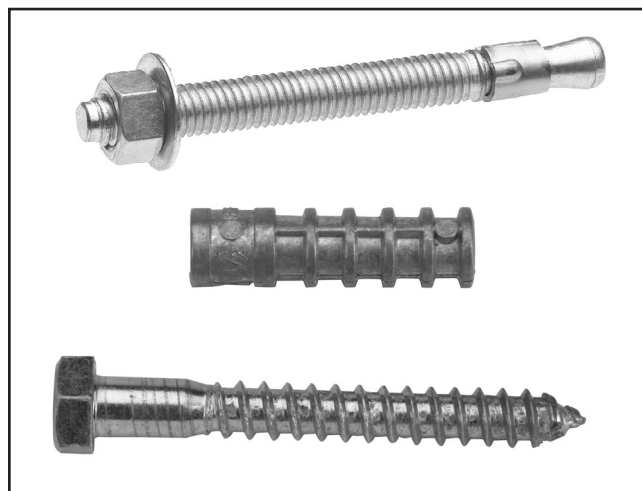

Figure 6. Typical fasteners for mounting to concrete floors.



Assembly

Assembling the Model T20797 consists of installing the foot pedal assembly and the front and rear extension arms assemblies. Installation of the extension arms is an optional step that is dependent on the operations you plan to perform.

To assemble the foot shear:

1. Attach the blade yokes to the arms of the foot pedal with the M14-2 x 50 bolts, washers and nuts, and tighten in position (**Figure 7**).

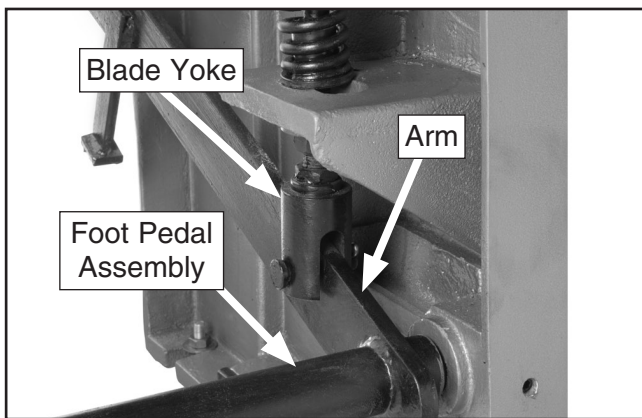

Figure 7. Foot pedal assembly.

2. Loosen, but do not remove the four cap screws on the front of the table.
3. Place the front extension rails over the cap screws and behind the flat washers (**Figure 8**).

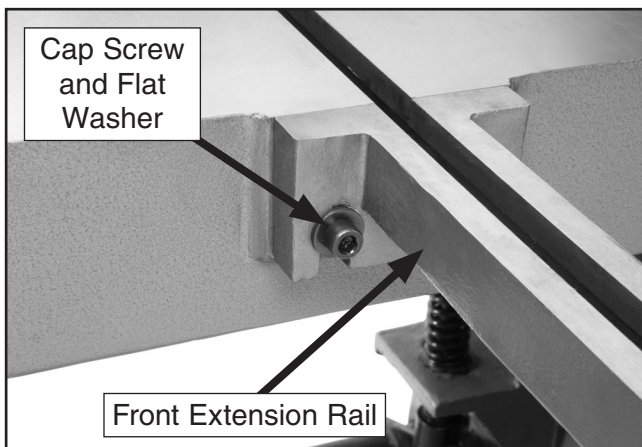

Figure 8. Front extension rail installed.

4. Line up the channel of the front extension rails with the channel on the table.
5. Make sure the ground flat surface on the front extension rail is flush with the top of the table surface.
6. Tighten the cap screws and check to make sure the alignment is still intact. If it is not, re-adjust as necessary.
7. Slide the front work stop into the extension rails. When the foot pedal, front extension rails, and work stops are installed, the machine should look like **Figure 9**.

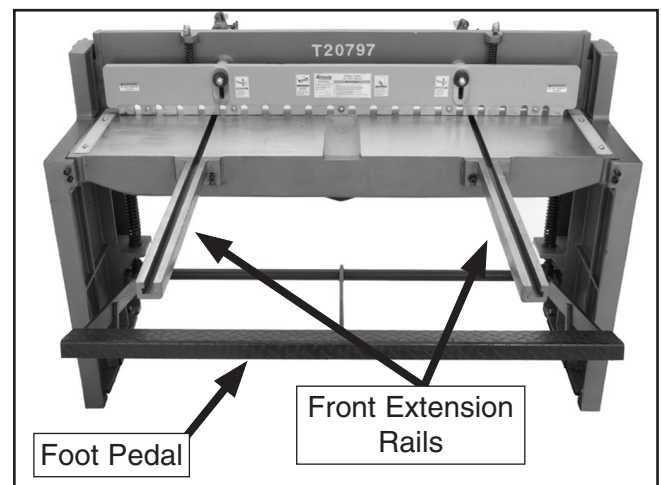

Figure 9. Foot pedal and front extension arms.



To install the rear extension rods (optional):

1. With the scales facing up, slide the rear extension rods into the holes in the back of the blade assembly.
2. Tighten the cap screws (**Figure 10**).

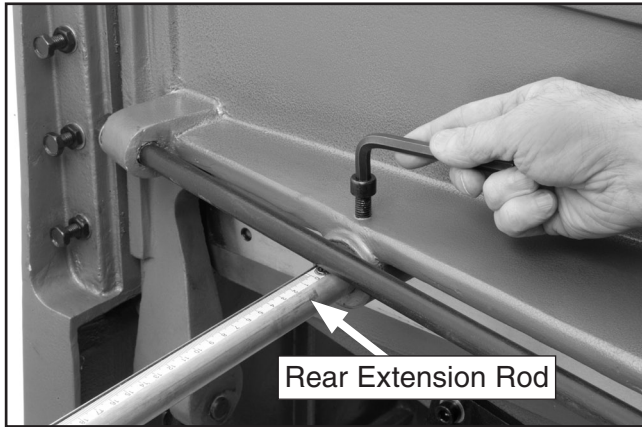

Figure 10. Installing rear extension rod.

3. Attach the rear stop bar to the rear extension rods as shown in **Figure 11**.

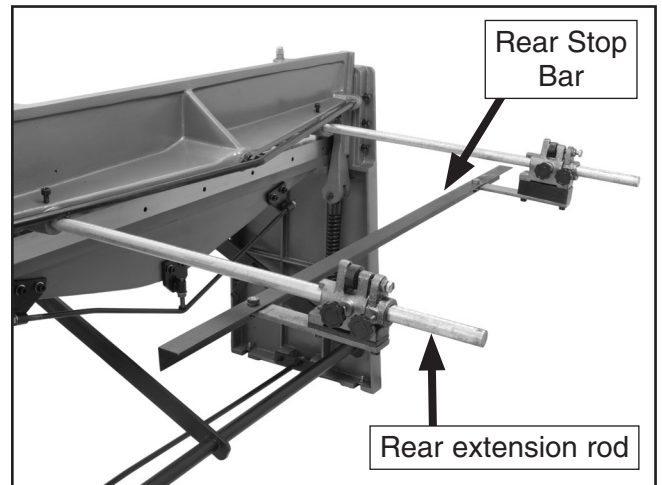
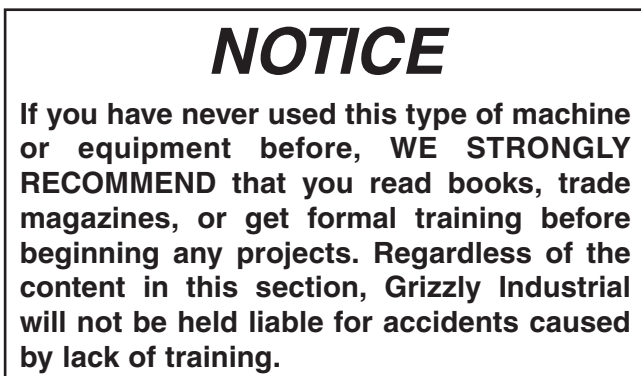
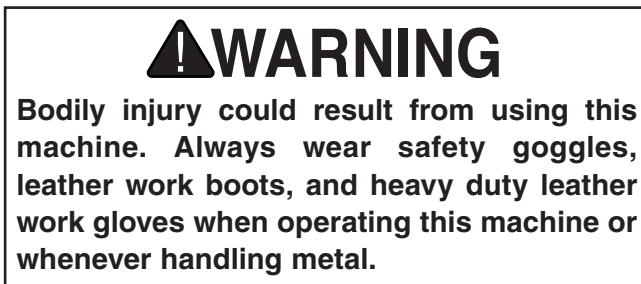
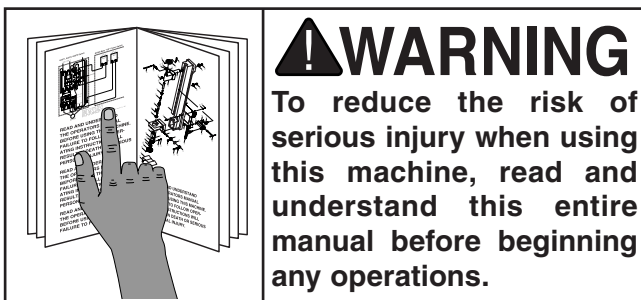
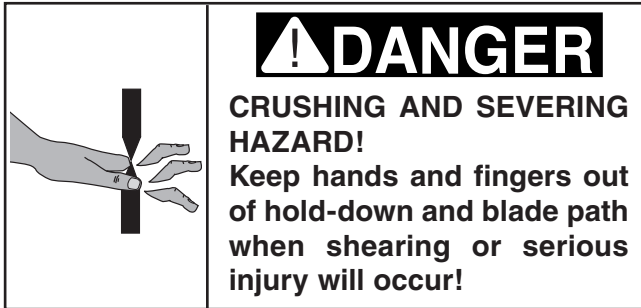

Figure 11. Installing rear extension rods.



SECTION 3: OPERATIONS

Operation Safety



Basic Controls

Use **Figures 12–13** and the descriptions below to familiarize yourself with the basic operations of the machine.

Foot Pedal: Lowers the top blade downward when stepped upon.

Front and Rear Extensions: Support large workpieces and provide mounting points for the stops. Micro adjusters allow for fine adjustments.

Rear Stops: Align workpieces when performing repetitive operations.

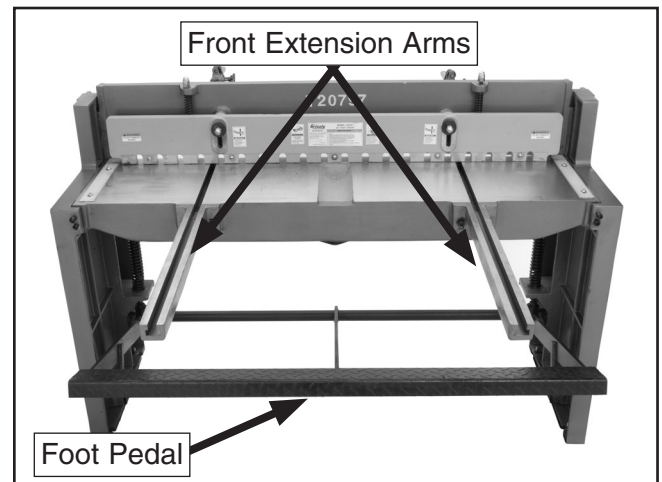

Figure 12. Basic controls.

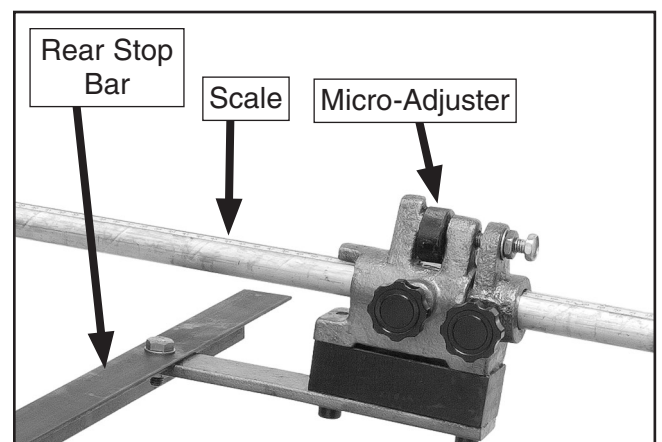

Figure 13. Basic controls (continued).



Stops & Guides

The front stop and angle guide are quickly adjusted by wing nuts on the top of the stops. The rear extension arms have micro-adjusting stops (**Figure 14**) that allow you to fine tune your cut length. For the most accurate cuts, make sure that you have at least one square edge up against a stop.

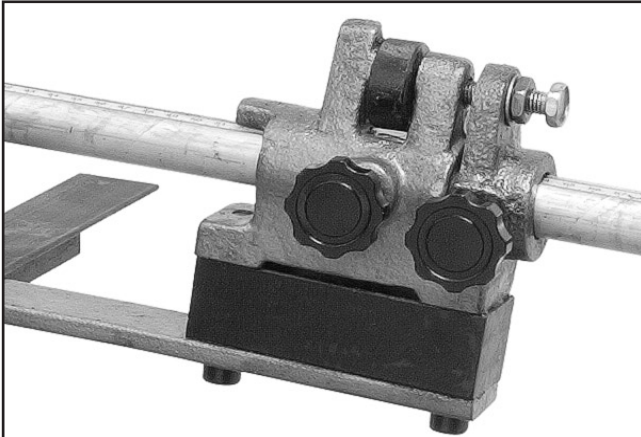

Figure 14. Micro-adjusting stop.

Operation Overview

To use the foot shear:

1. Mark the workpiece along the line to be cut.
2. Place the workpiece on the table and adjust it so that the line made in **Step 1** is aligned with the edge of the bottom blade.

—If you are making repetitive cuts, place a stop against the workpiece. For each cut that follows, place the workpiece against the stop to create the same cut.
3. Step down on the foot pedal until the cut is complete.

—If the workpiece is longer than the extension arms can support, have an assistant wear heavy leather gloves and boots and support the workpiece while it is cut, so it doesn't fall to the floor and get damaged.

Shearing Tips

- For the best results, never cut any piece narrower than eight times the thickness of the material. For example ½" strip of 0.06" mild steel.
- Keep the blade gap to the smallest distance possible.
- The table below lists other materials and the equivalent decimal thicknesses that can be used on this shear.

	16 GA.	18 GA.	20 GA.
Mild Steel	0.060"	0.048"	0.036"
Stainless			0.031"
Cold Rolled	0.048"	0.035"	0.030"
Aluminum	0.100"	0.090"	0.063"
Brass, Yellow			
• Soft	0.072"	0.064"	0.051"
• 1/2 Hard	0.064"	0.051"	0.036"
• Hard	0.054"	0.051"	0.036"
Bronze, Phosphor			
• Annealed	0.064"	0.051"	0.040"
Copper			
• Soft	0.072"	0.064"	0.051"
• Hard	0.064"	0.051"	0.040"

Figure 15. Equivalent material thickness chart.

Finger Guard

A clear plastic finger guard is fixed to the front of the hold-down. Under no circumstances should this guard be removed. It will keep your fingers away of the blades but it will *NOT* protect you from the crushing force of the hold-down. Never put any part of your body under or behind this finger guard! Be sure to keep the guard in working order and maintain the position and readability of all the warning labels.



Hold-Down Adjustment

The hold-down functions as a safety device to secure the workpiece while it is being sheared and to help prevent the operator's fingers from getting in the blade cutting path. The hold-down must be adjusted properly to perform these functions.

The ideal adjustment provides only enough clearance to slide the workpiece under the workstop. For practicality and safety, the workstop should be adjusted to provide approximately $\frac{1}{8}$ " clearance.

Items Needed	Qty.
Sheet Stock $\frac{1}{8}$ "	1
Socket or Wrench 19mm.....	1

To adjust the hold-down:

1. Tighten the hex nuts on the springs to raise the hold-down off the table (**Figure 16**).

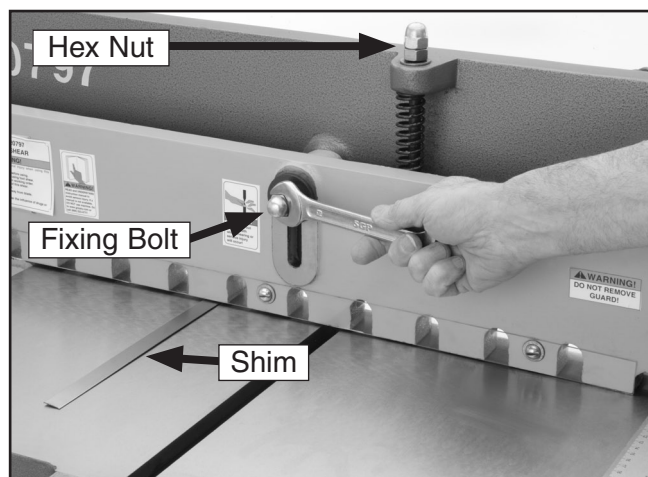

Figure 16. Tightening hold-down.

2. Insert the shim stock under the hold-down, then loosen the hex nut to lower the hold-down until it makes contact with the shim.
3. Repeat **Step 2** at the other side of the shear.
4. Check the gap to make sure the distance is equal across the length of the hold-down.

Tip: To avoid scratching the surface of your workpiece, apply thin rubber pads to the bottom of the hold-down fingers.

Blade Adjustment

The blade adjustment has been made at the factory before shipment. A few test cuts will determine if this adjustment is satisfactory for your needs. If it is, you are ready to start using your foot shear. However, you may find it necessary to check the blade adjustment before continuing. Depending on how often you change the type and gauge of material you cut, this adjustment process may become routine.

Tools Required	Qty.
Socket or Wrench 24mm.....	1
Hex Wrench 8mm.....	1
Feeler Gauge 0.002"	1

To perform the blade adjustment:

1. Loosen, but do not remove the two table bolts and table adjustment screws on both sides of the foot shear (see **Figure 17**).

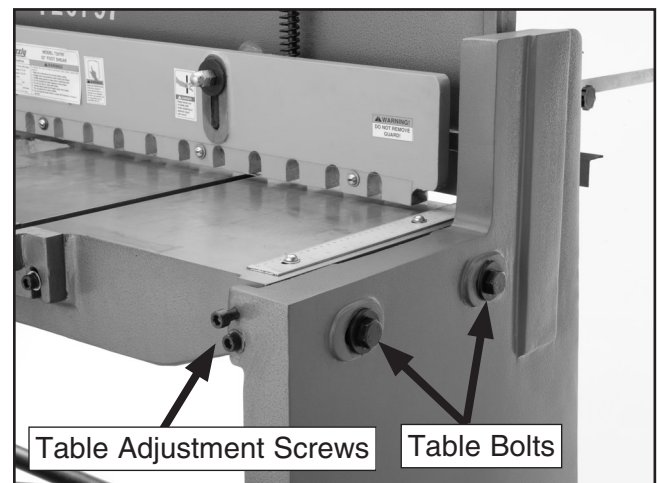

Figure 17. Adjustment screws.

2. Using the foot pedal, lower the blade and hold it in position. (It may help to have your assistant do this step.)
3. Turn the table adjustment screws to move the table and fixed blade until the fixed blade makes light contact with the moving blade.

NOTICE: The moving blade should never overlap the fixed blade. This will cause damage to both.



4. Looking behind the hold-down, make sure the two blades surfaces appear to make light contact all the way across the length.

—If they do, proceed to the next step.

—If you observe a gap between the two blade surfaces, move to the next section **Adjusting Blade Bow** section.

5. Using a sheet of paper, confirm that you have proper contact by making several cuts along the length of the blade. The shear should cut through the paper cleanly.
6. Turn the table adjustment screws to move the fixed blade away from the moving blade so you have a gap of 0.002". Check this measurement with a feeler gauge as shown in **Figure 18**.

Note: 0.002" is a good starting point for most operations. The gap width will change, however, depending on the type and gauge of the material being sheared. This is a trial-and-error process. Test with scrap pieces until you achieve satisfactory results.

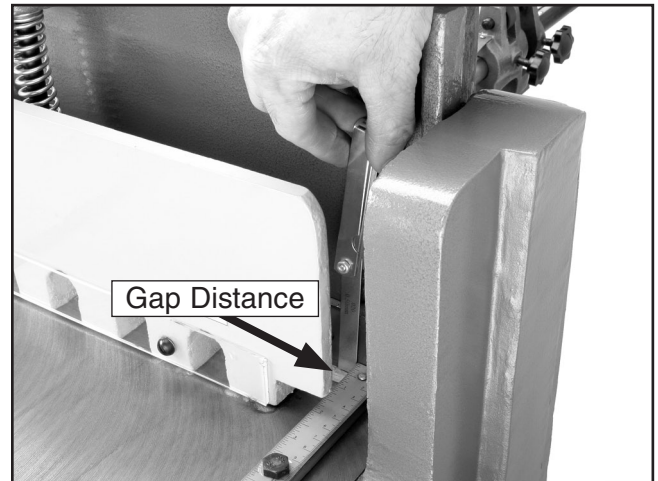

Figure 18. Measuring gap between blades.

7. Repeat **Step 6** on the other side so the gap is uniform across the length of the blade.
8. Tighten the four table bolts and double check the gap to make sure it has not changed.



SECTION 4: ACCESSORIES

G5618—Deburring Tool with two Blades

G5619—Extra Aluminum Blades

G5620—Extra Brass and Cast Iron Blade

The quickest tool for smoothing freshly sheared metal edges. Comes with two blades, one for steel and aluminum and one for brass and cast iron.



Figure 19. G5618 Deburring tool.

H3153—Pigskin Palm Gloves

H3154—Lined Pigskin Palm Gloves

Durable pigskin leather is combined with cloth backs for true comfort. One size fits many.

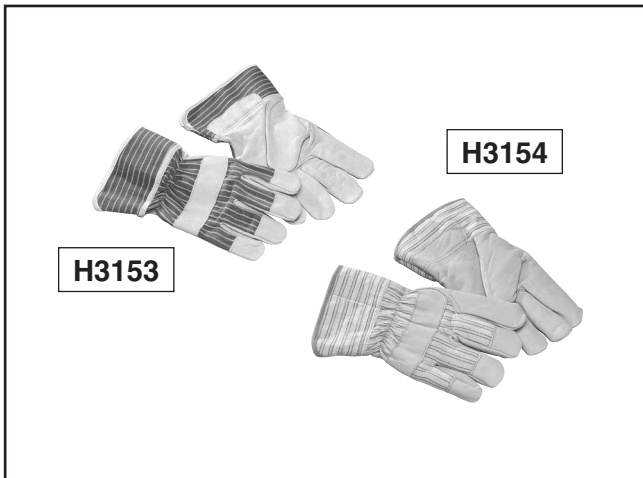

Figure 20. Work gloves.

H5614—Wire Gauge US Standard

Calibrated for sheet metal sized from 0 to 30 gauge. The front is marked with gauge sizes, the back is marked with actual inch measurements.



Figure 21. H5614 Wire Gauge.

G5562—SLIPIT® 1 Qt. Gel

G5563—SLIPIT® 12 oz Spray

G2871—Boeshield® T-9 12 oz Spray

G2870—Boeshield® T-9 4 oz Spray

H3788—G96® Gun Treatment 12 oz Spray

H3789—G96® Gun Treatment 4.5 oz Spray



Figure 22. Recommended products for protecting unpainted cast iron/steel part on machinery.

Call 1-800-523-4777 To Order



G4956—Super Nibbler

The super nibbler is just the ticket for cutting sheet metal up to $\frac{3}{64}$ " thick. Extremely narrow headed design allows cuts in hard-to-reach areas, yet still features a safety guard to prevent flying splinters. 10 $\frac{1}{4}$ " overall.



Figure 23. Model G4956 Super Nibbler.

H5958—Sheet Metal Pliers

For bending and forming sheet metal. Jaws are 3 $\frac{1}{2}$ " wide. Rubber grips. Overall length is 8". Ideal for HVAC Installers.



Figure 24. Model H5958 Sheet Metal Pliers.

G8781—4 $\frac{1}{2}$ " Suction Cup

Handle plate glass, glass mirrors and sheet metal with safety and security. Simple hand lever action provides tremendous gripping power on any flat, smooth material. Buy two Suction Cups for two-handed control!



Figure 25. Model G8781 4 $\frac{1}{2}$ " Suction Cup.

H6131—Heavy-Duty Hand Riveter

Whether you're a full time sheet metal fabricator, or just making occasional repairs, you might as well invest in the best. This Heavy-Duty Hand Riveter with reinforced cast construction will be one of your most dependable tools.



Figure 26. Model H6131 Heavy-Duty Hand Riveter.

Call 1-800-523-4777 To Order



SECTION 5: MAINTENANCE

Schedule

For optimum performance from your machine, follow this maintenance schedule.

Daily Check:

- Loose bolts, cracked welds, castings, or fingers.
- Worn or damaged pins.
- Any other unsafe condition.

Unpainted Cast Iron

To prevent rust, all unpainted cast iron surfaces on the Model T20798 should be regularly maintained with a surface protectant like G96® Gun Treatment (Model H3788) or Boeshield® T-9 (Model G2871).

Lubrication

Four main areas need to be lubricated:

- Shearing blades (**Figure 27**).
- Micro adjusting stop assembly (**Figure 28**).
- Gibs and slides (**Figure 29**).
- Foot pedal linkage (**Figure 30**).

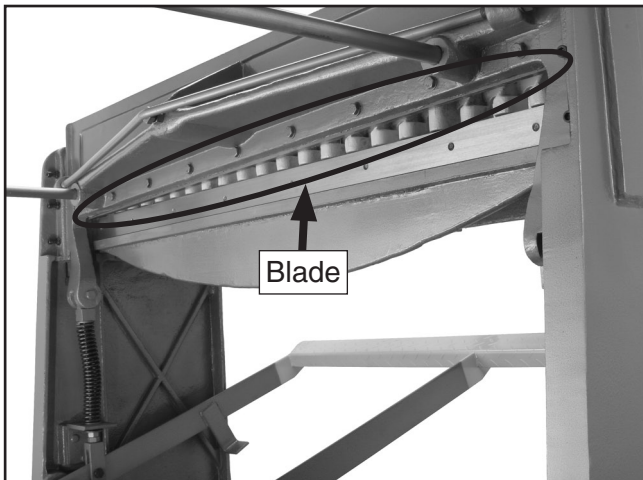

Figure 27. Blade lubrication.

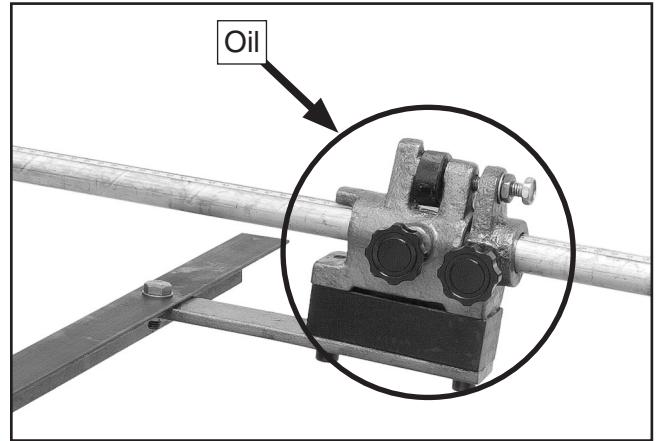

Figure 28. Micro-adjusting stop lubrication.

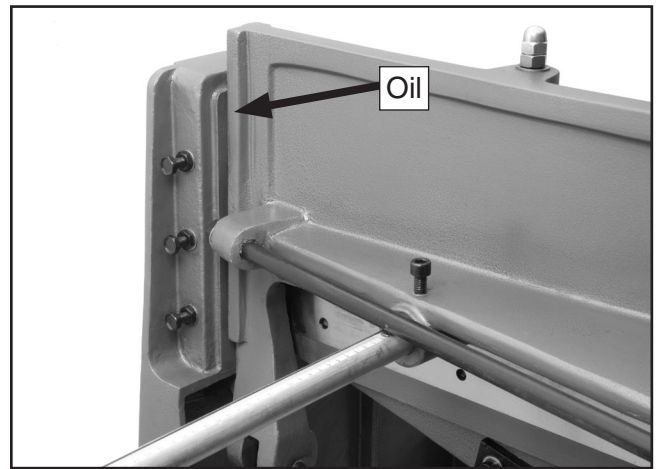

Figure 29. Gib and slide lubrication.

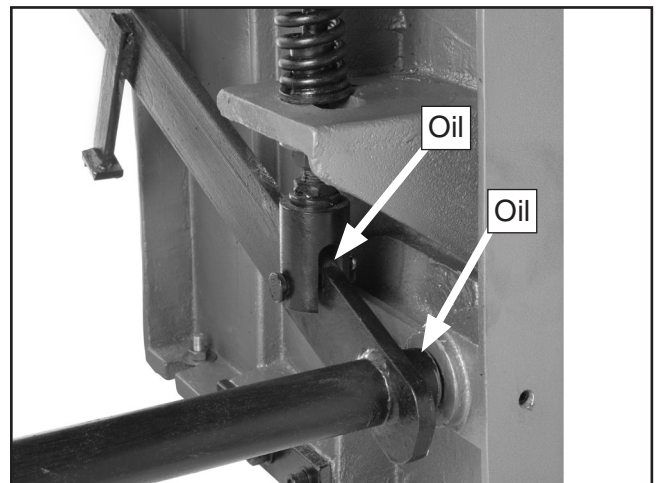

Figure 30. Linkage lubrication.



SECTION 6: SERVICE

Review the troubleshooting and procedures in this section to fix your machine if a problem develops. If you need replacement parts or you are unsure of your repair skills, then feel free to call our Technical Support at (570) 546-9663.

Troubleshooting

Operations

Symptom	Possible Cause	Possible Solution
Won't cut material.	<ol style="list-style-type: none"> 1. Improper blade gap distance. 2. Cut exceeds machine capacities. 	<ol style="list-style-type: none"> 1. Widen gap to accommodate thicker gauge material. 2. Make cuts within the capacity of the machine.
Cuts aren't square.	<ol style="list-style-type: none"> 1. Blade gap unequal across length. 2. Too much bow in blade. 3. Inadequate hold-down pressure. 4. Uneven contact with guides. 	<ol style="list-style-type: none"> 1. Adjust blade gap to be equal across length (Page 16). 2. Correct blade bow (Page 22). 3. Adjust gap of hold-down (Page 16). 4. Maintain consistent contact with guides.
Poor quality of cuts, ripping or tearing.	<ol style="list-style-type: none"> 1. Dull blades. 2. Poor blade gap set up. 3. Loose gibs. 	<ol style="list-style-type: none"> 1. Replace or sharpen blades. 2. Adjust blade set up (Page 16). 3. Remove play from gibs.

Blade Sharpening/ Replacement

Tools Required	Qty.
Socket or Wrench 17mm	1

Note: After new blades are installed or old blades are sharpened, they must be adjusted.

The blades can be removed by removing the hex bolts that attach the blades to the castings (see **Figure 31**).

The moving blade has two cutting edges that are ground with a 2° edge relief. Reverse the blade to expose the new cutting edge as soon as one edge is dull. The blade can be sharpened on a surface grinder by grinding both wide sides of the blade.

The fixed blade has one cutting edge with a 2° edge relief and a 1° face relief. It can be resharpened on a surface grinder by grinding the wide side of the blade.

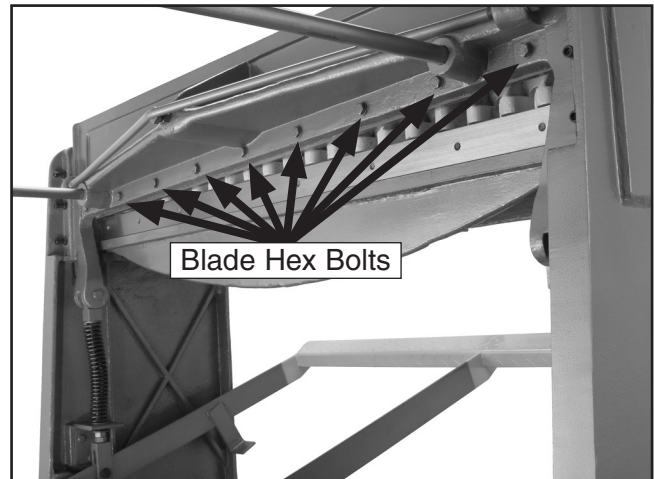

Figure 31. Blade bolts.



Adjusting Blade Bow

Tools Required	Qty.
Open-end Wrench 24mm.....	1

The blade bow of the moving blade is adjusted by loosening or tightening the bow bolt at the center of the straightening rod (**Figure 33**). Observe the change in the gap when the moving blade is just below the top of the fixed blade. For optimum performance, the gap must be consistent across the entire length of the blades. After making adjustments to the bow, repeat the **Blade Adjustment** section. Perform a paper shear test to check the blade bow performance.

- If the shear cuts paper on the ends but not the center, turn the bow bolt clockwise until paper can be easily cut across the length.
- If the shear cuts paper at the center but not the ends, turn the bow bolt counter-clockwise until the paper can be easily cut across the length.



Figure 32. Example of a paper shear test.

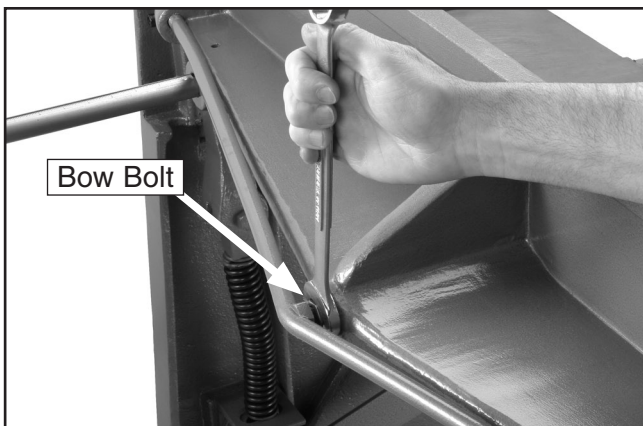

Figure 33. Adjusting bow bolt.

Gib Adjustment

Tools Required	Qty.
Open-end Wrench 14mm.....	2

When adjusting gibs, keep in mind that the goal of gib adjustment is to remove unnecessary slide movement without causing them to bind. Loose gibs may allow play in the moving blade resulting in poor cuts on the workpiece and undue wear on the slide. Over-tightening will make lowering the foot pedal difficult and wear out the slide.

Loosen the jam nuts, then tighten each gib bolt (**Figure 34**) until it is snug. Then back off each bolt $\frac{1}{8}$ turn and retighten the jam nuts. Test for binding or play after each adjustment by pushing and pulling the top of the cutter bar.

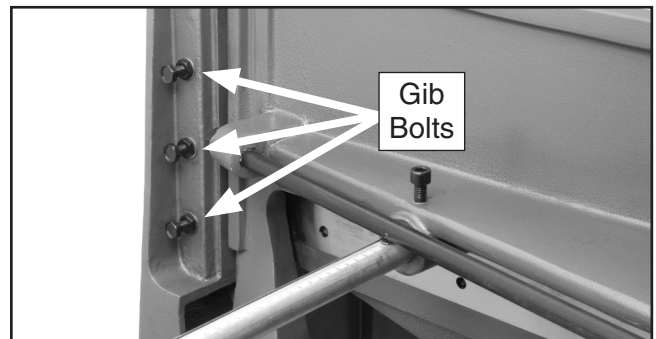

Figure 34. Gib bolt location.



SECTION 7: PARTS

Shear Assembly Breakdown

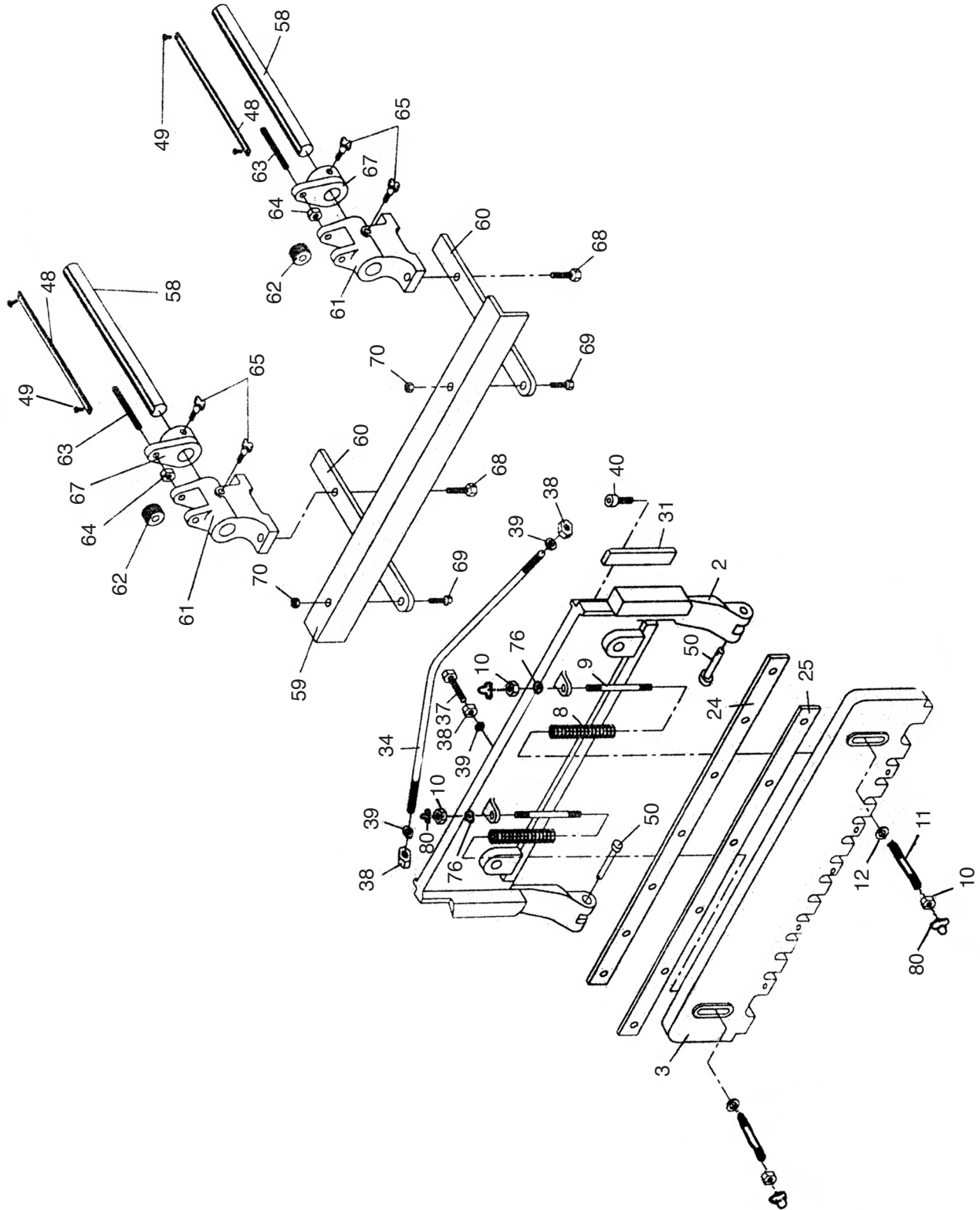
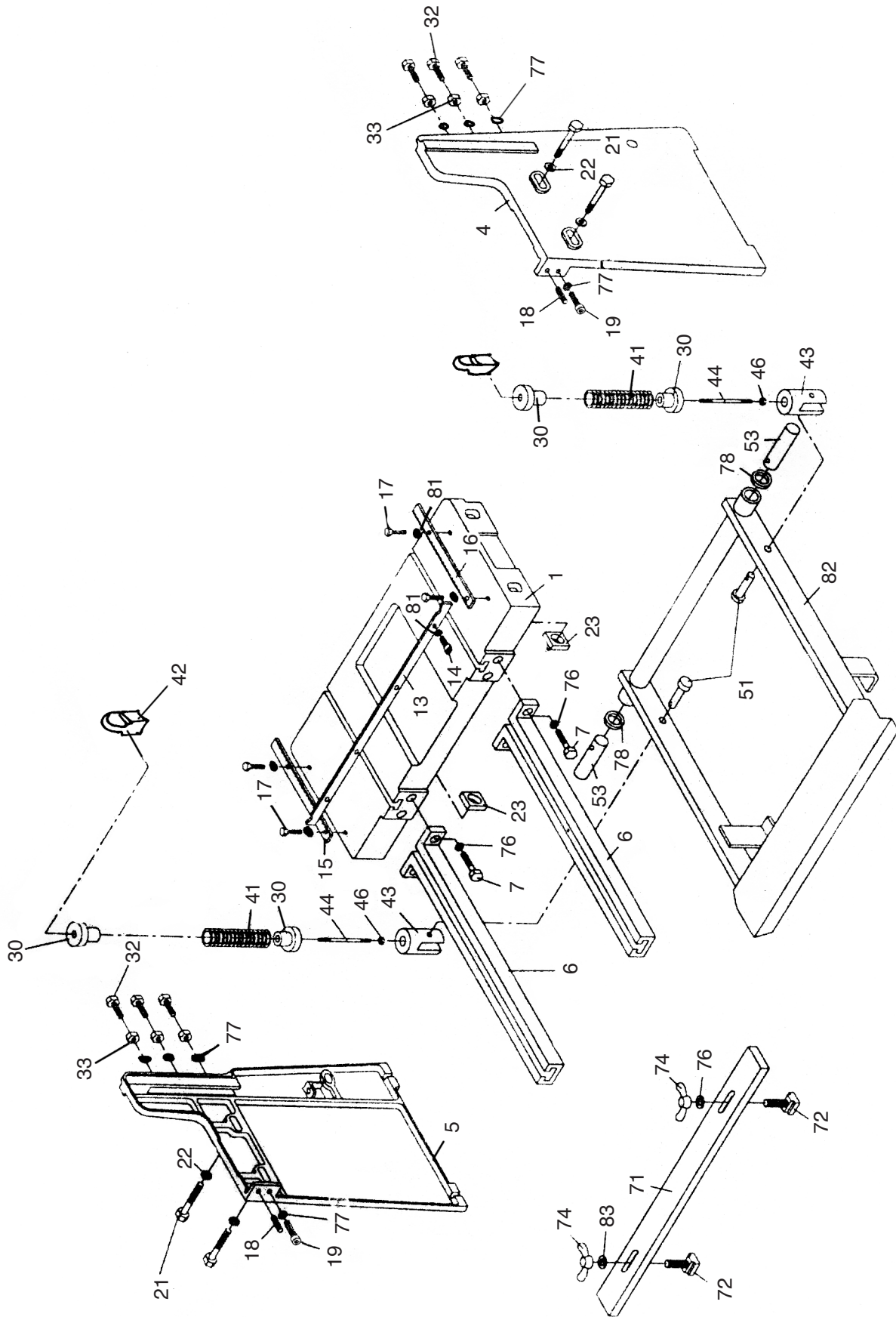

Table Assembly Breakdown



Parts List

REF	PART #	DESCRIPTION
1	PT20797001	TABLE
2	PT20797002	CUTTER BAR
3	PT20797003	HOLD DOWN
4	PT20797004	RH SIDE PANEL
5	PT20797005	LH SIDE PANEL
6	PT20797006	FRONT ARM EXTENSION
7	PB24M	HEX BOLT M12-1.75 X 45
8	PT20797008	COMPRESSION SPRING
9	PT20797009	HOLD DOWN SPRING STUD
10	PN09M	HEX NUT M12-1.75
11	PB141M	HEX BOLT M12-1.75 X 80
12	PW10M	FLAT WASHER 14MM
13	PT20797013	FINGER GUARD
14	PSB58M	CAP SCREW M8-1.25 X 12
15	PT20797015	LH TABLE SCALE
16	PT20797016	RH TABLE SCALE
17	PB09M	HEX BOLT M8-1.25 X 20
18	PSB84M	CAP SCREW M10-1.5 X 35
19	PSB47M	CAP SCREW M10-1.5 X 40
21	PB113M	HEX BOLT M16-2 X 120
22	PW27M	FLAT WASHER 17MM
23	PT20797023	SQUARE NUT M16-1.5
24	PT20797024	MOVING KNIFE (UPPER)
25	PT20797025	FIXED KNIFE (LOWER)
30	PT20797030	SPRING CAP
31	PT20797031	GIB
32	PB144M	HEX BOLT M10-1.5 X 55
33	PN02M	HEX NUT M10-1.5
34	PT20797034	STRAIGHTENER ROD
37	PB114M	HEX BOLT M16-1.5 X 80
38	PN05M	HEX NUT M16-1.5
39	PW08M	FLAT WASHER 16MM

REF	PART #	DESCRIPTION
40	PSB72M	CAP SCREW M10-1.5 X 30
41	PT20797041	COMPRESSION SPRING
42	PT20797042	SWIVEL TOP
43	PT20797043	SWIVEL BOTTOM
44	PT20797044	STUD
46	PN13M	HEX NUT M16-2
48	PT20797048	SCALE
49	PS07M	PHLP HD SCR M4-.7 X 8
50	PT20797050	TOP SWIVEL SCREW
51	PT20797051	BOTTOM SWIVEL SCREW
53	PT20797053	HINGE PIN
58	PT20797058	BACK GAUGE ROD
59	PT20797059	BACK GAUGE STOP
60	PT20797060	EXTENSION BAR
61	PT20797061	ADJUSTABLE BLOCK
62	PT20797062	ADJUSTABLE DIAL
63	PT20797063	ADJUSTABLE SCREW ROD
64	PN02M	HEX NUT M10-1.5
65	PT20797065	LOCK KNOB
67	PT20797067	ROD BRACKET
68	PSB64M	CAP SCREW M10-1.5 X 25
69	PB32M	HEX BOLT M10-1.5 X 25
70	PN02M	HEX NUT M10-1.5
71	PT20797071	FRONT STOP
72	PT20797072	T-NUT STUD M12-1.75
74	PT20797074	WING NUT M12-1.75
76	PW06M	FLAT WASHER 12MM
77	PW04M	FLAT WASHER 10MM
78	PT20797078	SPACER WASHER 27MM
80	PN26M	ACORN NUT M12-1.75
81	PW01M	FLAT WASHER 8MM
82	PT20797082	FOOT PEDAL



Labels Breakdown & List

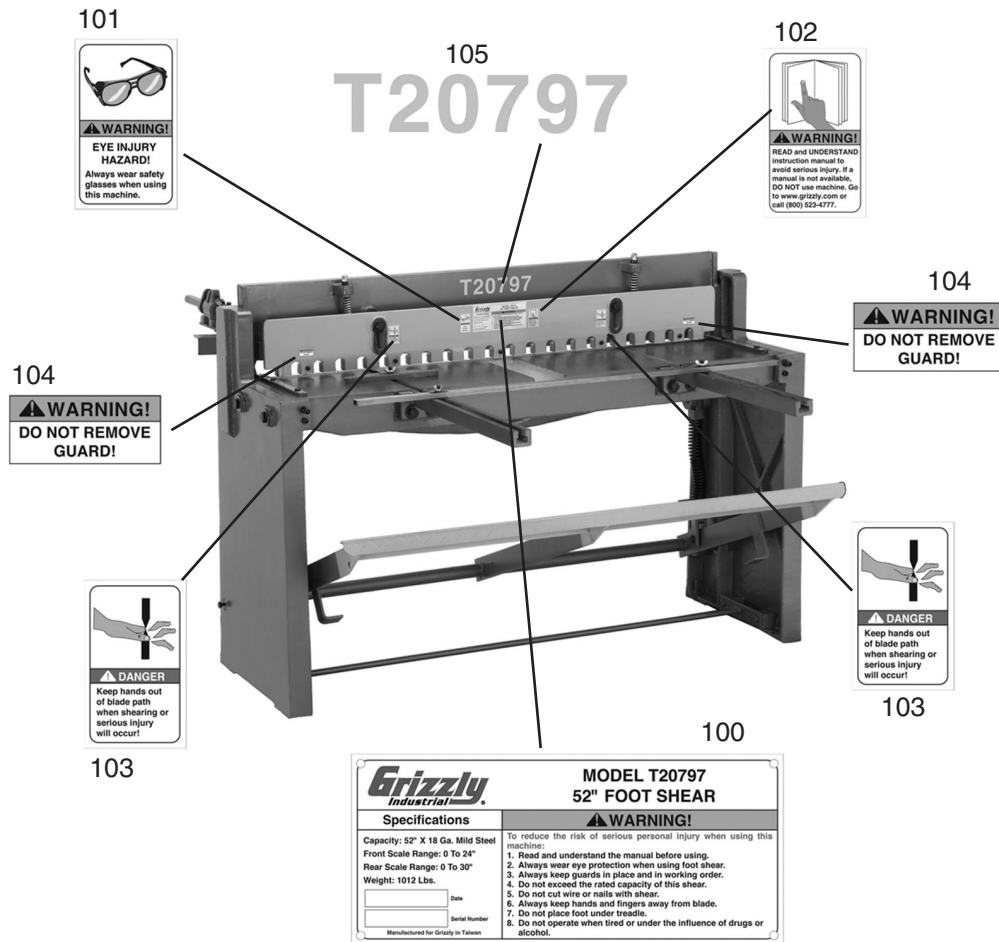

Parts List

REF	PART #	DESCRIPTION
100	PT20797100	MACHINE ID LABEL
101	PLABEL-11	SAFETY GLASSES LABEL
102	PLABEL-12A	READ MANUAL LABEL

REF	PART #	DESCRIPTION
103	PT20797103	SHEARED FINGERS LABEL
104	PT20797104	GUARD NOTICE LABEL
105	PT20797105	MODEL NUMBER LABEL

!WARNING

Safety labels warn about machine hazards and ways to prevent injury. The owner of this machine **MUST** maintain the original location and readability of the labels on the machine. If any label is removed or becomes unreadable, **REPLACE** that label before using the machine again. Contact Grizzly at (800) 523-4777 or www.grizzly.com to order new labels.





WARRANTY CARD

Name _____
 Street _____
 City _____ State _____ Zip _____
 Phone # _____ Email _____ Invoice # _____
 Model # _____ Order # _____ Serial # _____

The following information is given on a voluntary basis. It will be used for marketing purposes to help us develop better products and services. **Of course, all information is strictly confidential.**

1. How did you learn about us?

Advertisement Friend Catalog
 Card Deck Website Other:

2. Which of the following magazines do you subscribe to?

<input type="checkbox"/> Cabinet Maker	<input type="checkbox"/> Popular Mechanics	<input type="checkbox"/> Today's Homeowner
<input type="checkbox"/> Family Handyman	<input type="checkbox"/> Popular Science	<input type="checkbox"/> Wood
<input type="checkbox"/> Hand Loader	<input type="checkbox"/> Popular Woodworking	<input type="checkbox"/> Wooden Boat
<input type="checkbox"/> Handy	<input type="checkbox"/> Practical Homeowner	<input type="checkbox"/> Woodshop News
<input type="checkbox"/> Home Shop Machinist	<input type="checkbox"/> Precision Shooter	<input type="checkbox"/> Woodsmith
<input type="checkbox"/> Journal of Light Cont.	<input type="checkbox"/> Projects in Metal	<input type="checkbox"/> Woodwork
<input type="checkbox"/> Live Steam	<input type="checkbox"/> RC Modeler	<input type="checkbox"/> Woodworker West
<input type="checkbox"/> Model Airplane News	<input type="checkbox"/> Rifle	<input type="checkbox"/> Woodworker's Journal
<input type="checkbox"/> Modeltec	<input type="checkbox"/> Shop Notes	<input type="checkbox"/> Other:
<input type="checkbox"/> Old House Journal	<input type="checkbox"/> Shotgun News	

3. What is your annual household income?

\$20,000-\$29,000 \$30,000-\$39,000 \$40,000-\$49,000
 \$50,000-\$59,000 \$60,000-\$69,000 \$70,000+

4. What is your age group?

20-29 30-39 40-49
 50-59 60-69 70+

5. How long have you been a woodworker/metalworker?

0-2 Years 2-8 Years 8-20 Years 20+ Years

6. How many of your machines or tools are Grizzly?

0-2 3-5 6-9 10+

7. Do you think your machine represents a good value? Yes No

8. Would you recommend Grizzly Industrial to a friend? Yes No

9. Would you allow us to use your name as a reference for Grizzly customers in your area?

Note: We never use names more than 3 times. Yes No

10. Comments: _____

CUT ALONG DOTTED LINE

FOLD ALONG DOTTED LINE



Place Stamp Here



GRIZZLY INDUSTRIAL, INC.
P.O. BOX 2069
BELLINGHAM, WA 98227-2069



FOLD ALONG DOTTED LINE

Send a Grizzly Catalog to a friend:

Name _____
Street _____
City _____ State _____ Zip _____

TAPE ALONG EDGES--PLEASE DO NOT STAPLE

WARRANTY AND RETURNS

Grizzly Industrial, Inc. warrants every product it sells for a period of **1 year** to the original purchaser from the date of purchase. This warranty does not apply to defects due directly or indirectly to misuse, abuse, negligence, accidents, repairs or alterations or lack of maintenance. This is Grizzly's sole written warranty and any and all warranties that may be implied by law, including any merchantability or fitness, for any particular purpose, are hereby limited to the duration of this written warranty. We do not warrant or represent that the merchandise complies with the provisions of any law or acts unless the manufacturer so warrants. In no event shall Grizzly's liability under this warranty exceed the purchase price paid for the product and any legal actions brought against Grizzly shall be tried in the State of Washington, County of Whatcom.

We shall in no event be liable for death, injuries to persons or property or for incidental, contingent, special, or consequential damages arising from the use of our products.

To take advantage of this warranty, contact us by mail or phone and give us all the details. We will then issue you a "Return Number," which must be clearly posted on the outside as well as the inside of the carton. We will not accept any item back without this number. Proof of purchase must accompany the merchandise.

The manufacturers reserve the right to change specifications at any time because they constantly strive to achieve better quality equipment. We make every effort to ensure that our products meet high quality and durability standards and we hope you never need to use this warranty.

Please feel free to write or call us if you have any questions about the machine or the manual.

Thank you again for your business and continued support. We hope to serve you again soon.

grizzly.com

TOOL WEBSITE

Buy Direct and Save with Grizzly® – Trusted, Proven and a Great Value!

*Visit Our Website Today And Discover
Why Grizzly® Is The Industry Leader!*

- SECURE ORDERING
- ORDERS SHIPPED WITHIN 24 HOURS
- E-MAIL RESPONSE WITHIN ONE HOUR

-OR-

Call Today For A **FREE**
Full Color Catalog

1-800-523-4777

