



**ASLAN**  
**MACHINE**  
www.aslanmachine.com

# USER'S MANUAL

AUTOMATIC UPCUT MITER SAW

**SA04-u450<sub>ma</sub> series**  
**a.k.a PKS-503**





**ASLAN**  
**MACHINE**  
www.aslanmachine.com

**Aslan Machine, Inc.**  
**A Distributor of Vinyl Window Machinery Products**

**204 23 Waters Point Lane**  
**Germantown, MD 20874, USA**

**Tel: +1 301 528 1696 • Fax: +1 301 542 0185**

**🖥️:www.aslanmachine.com    ✉️:info@aslanmachine.com**

## CONTENTS

<b>1. General Information</b>
1.1. Introduction
1.2. Distributor
<b>2. Machine's Description and Purpose of Use</b>
2.1. Machine's description
2.2. Technical features
2.3. Cutting diagram
2.4. Overall dimensions
2.5. Part lists and technical drawings for cutting mechanism
2.6. Electric and pneumatic control panel
<b>3. Safety</b>
3.1. Safety information
3.2. Accident prevention
3.3. General safety information
<b>4. Safely Transporting the Machine</b>
<b>5. Installing the machine</b>
5.1. Preparation
5.2. Electric connection
<b>6. Machine Safety Information</b>
<b>7. Operation</b>
7.1. Operating guide
7.2. Adjusting the air pressure
7.3. Checking angle adjustment of saw blade and bridge
<b>8. Safe installation of the saw blade</b>
<b>9. Maintenance</b>
9.1. Routine controls and maintenance
9.2. Maintenance at the end of the working day
<b>10. Troubleshooting Guide</b>
<b>11. Electric / pneumatic components</b>
11.1. Electric Components
11.2. Pneumatic Components
<b>12. Wiring Diagrams</b>
<b>13. Pictorial guide to use when ordering parts for this machine.</b>

## 1. GENERAL INFORMATION

### 1.1. INTRODUCTION

**This user's manual contains necessary information about the machine and its parts. Each machine operator should read these instructions carefully, and the machine should be operated after fully reading this manual.**

A safe and efficient use of this machine for long term depends on understanding and following the instructions contained in this manual. The technical drawings and details contained in this manual are a guide for the operator.

### 1.2. DISTRIBUTOR

Aslan Machine, Inc.  
20423 Waters Point Lane, Germantown, MD 20874  
Phone: +1-301-528-1696 Fax: +1-301-542-0185  
Website: [www.aslanmachine.com](http://www.aslanmachine.com)  
E-mail: [info@aslanmachine.com](mailto:info@aslanmachine.com)

In case of any technical problem, please contact us.

Technical identification label is on the front side of each machine.

The machine's serial number and manufacturing year are on the technical label.

## 2. MACHINE'S DESCRIPTION AND PURPOSE OF USE

### 2.1. MACHINE'S DESCRIPTION

This is an automatic up-cut saw with a circular saw blade for cutting PVC, aluminum and wood profiles at straight and miter angles. The operator can adjust the cutting speed of the saw blade via a knob on the air piston for the material type and the size.

The features of this machine:

- Cutting at fixed angles such as 15<sup>0</sup>, 22.5<sup>0</sup>, 30<sup>0</sup>, 45<sup>0</sup>, 90<sup>0</sup>, and at intermediate angles by setting arm. This machine has been designed according to CE Safety Directives.
- The movable back fence enables straight and miter cut for wide materials.
- The cutting speed can be adjusted manually for each material type.
- If the top safety cover and/or the front door is opened during a cutting operation, the power to the saw blade motor is interrupted for safety.
- After the cutting is finished, the saw blade moves down automatically.

Please include the following information in all your correspondences.

- \*Machine's model
- \*Machine's serial number
- \*Voltage and frequency
- \*Name of dealer where machine was purchased
- \*Date of purchase
- \*Description of the machine fault
- \*Average daily operation period

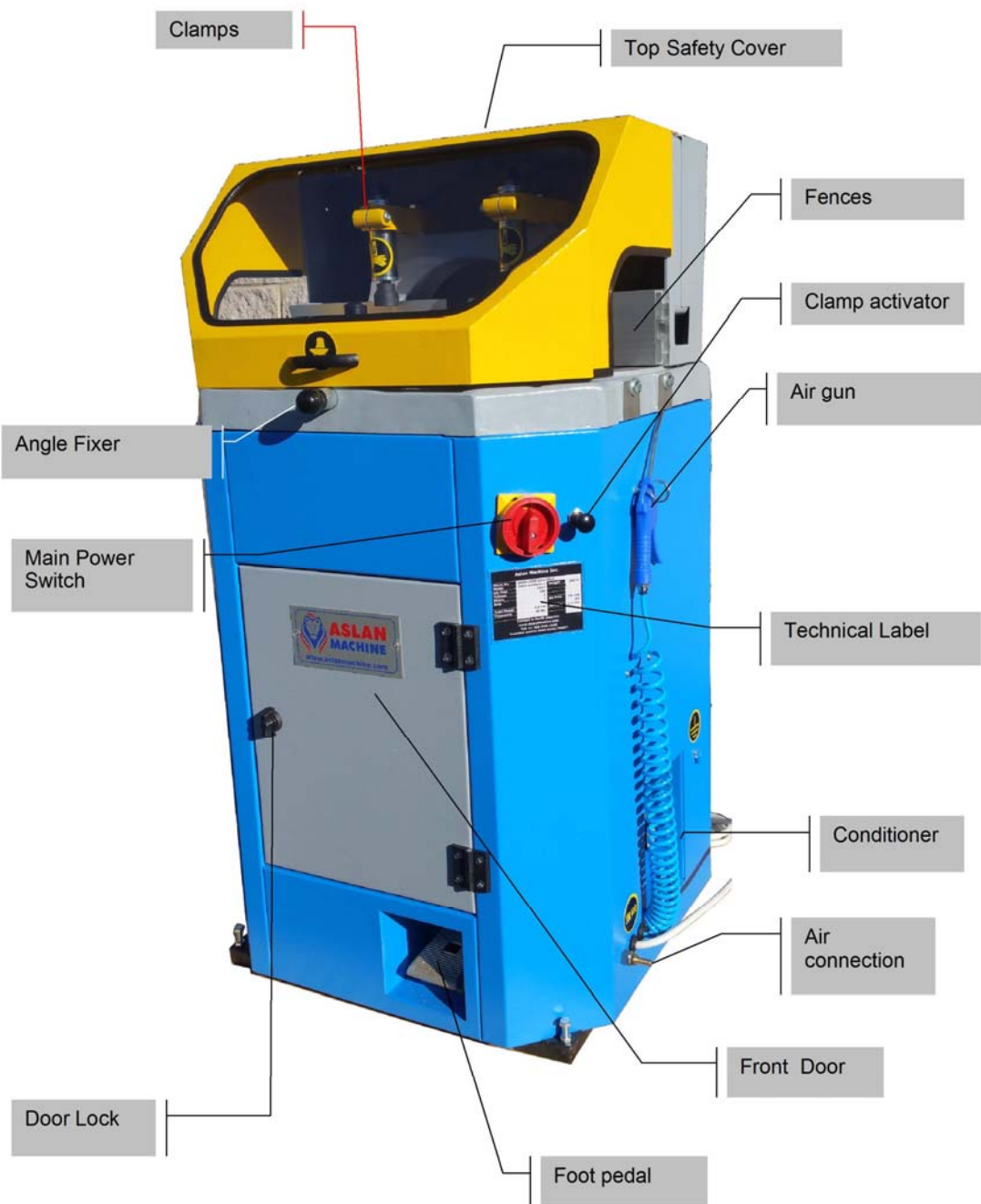
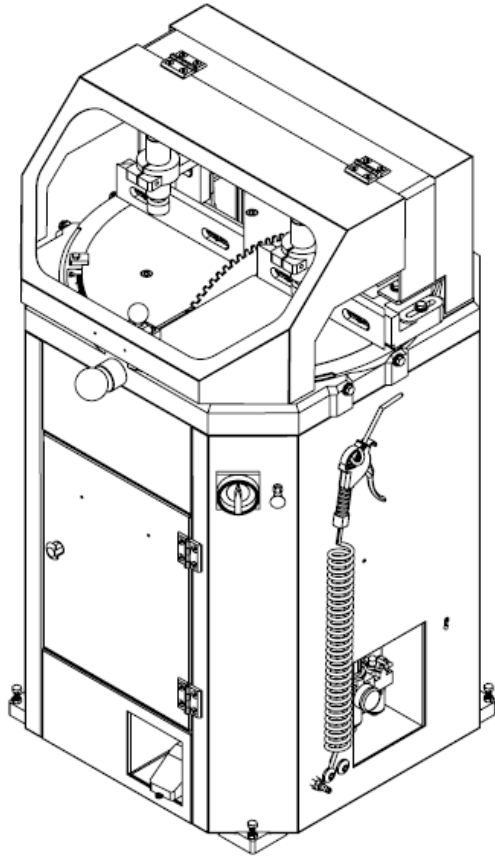

Figure – 1a General front view of the machine (SA04-u450ma-1 model) and its components.

Note: for safety reasons the motor does not start moving up until the top safety cover is closed and the clamps are activated.



SA04-u450ma-1

Works with foot pedal for cutting.

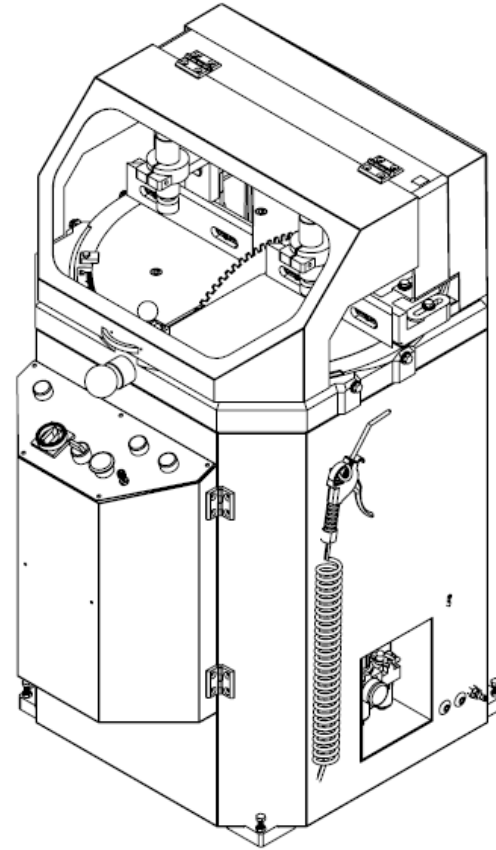

SA04-u450ma-2

Works with two-hand push buttons for cutting.

Figure – 1b General look of the two sub-models of SA04-u450ma series. Check which model you have.

## 2.2. TECHNICAL FEATURES











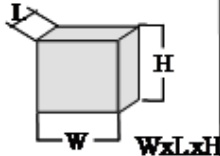

Technical Features (Metric)							
<b>SA04-u450<sub>ma-1</sub></b>	1.5kW 220V 60Hz 3-Phase	D=450 mm d=32 mm	3000 rpm	6-8 Bar	35 l/min	62x73x112 cm	130 kg
<b>SA04-u450<sub>ma-2</sub></b>	1.5kW 220V 60Hz 3-Phase	D=450 mm d=32 mm	3000 rpm	6-8 Bar	35 l/min	62x82x112 cm	130 kg
Technical Features (American)							
<b>SA04-u450<sub>ma-1</sub></b>	3 HP 3-Phase 220V/440V 60Hz	D=18" d=32 mm	3000 rpm	90-120 psi	1 CFM	25"x29"x44"	290 lb
<b>SA04-u450<sub>ma-2</sub></b>	3 HP 3-Phase 220V/440V 60Hz	D=18" d=32 mm	3000 rpm	90-120 psi	1 CFM	25"x33"x44"	290 lb

Table 1 – The technical features of this machine.



### 2.3. CUTTING DIAGRAM

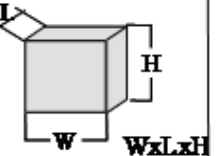
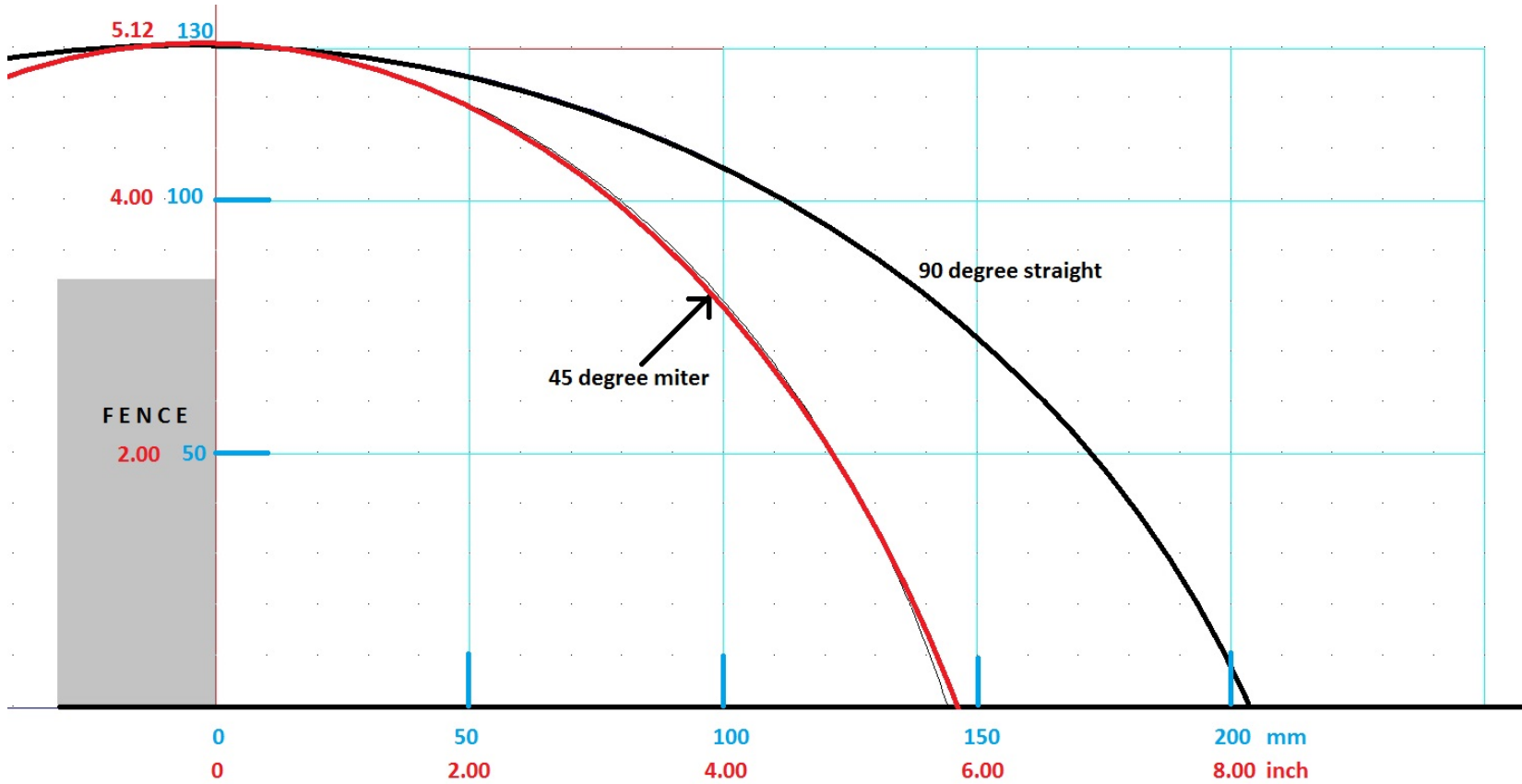

Figure - 2 Cutting Diagram with 450 mm saw blade.

## 2.4. OVERALL DIMENSIONS

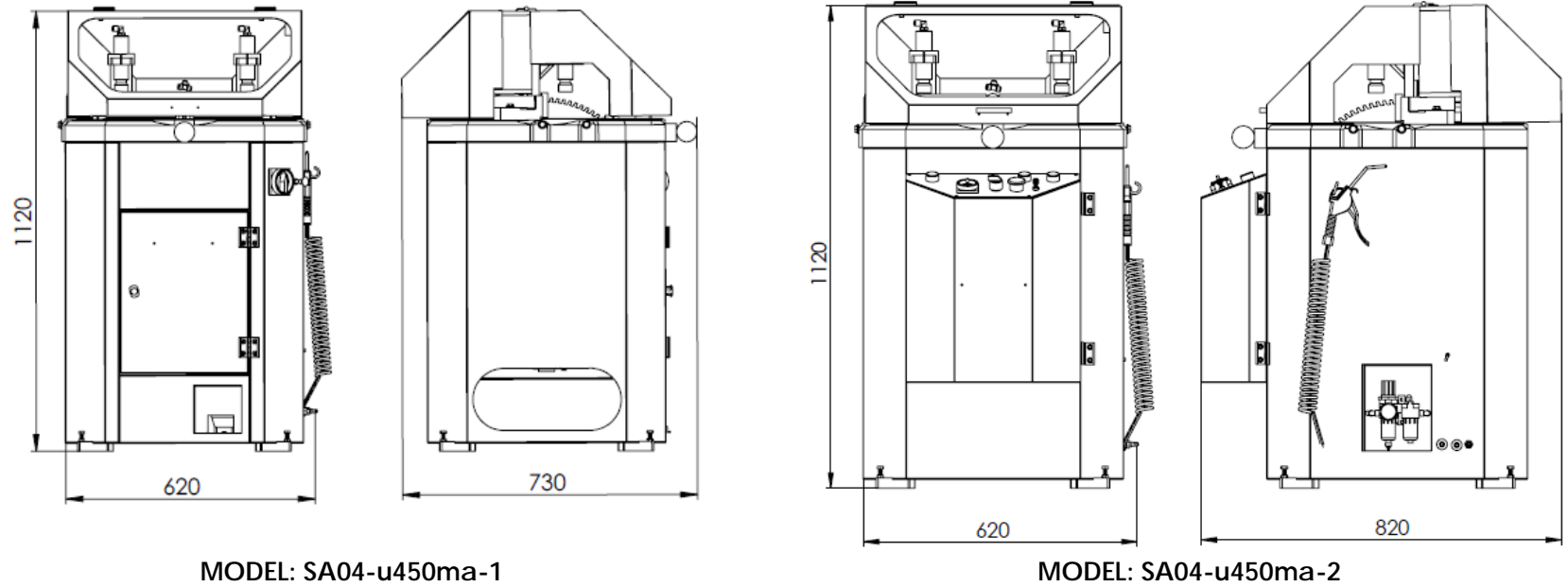

Figure - 3 Overall Dimensions, in terms of millimeters  
(1 inch = 25.4 mm)

2.5. TECHNICAL DRAWINGS AND PARTS LIST

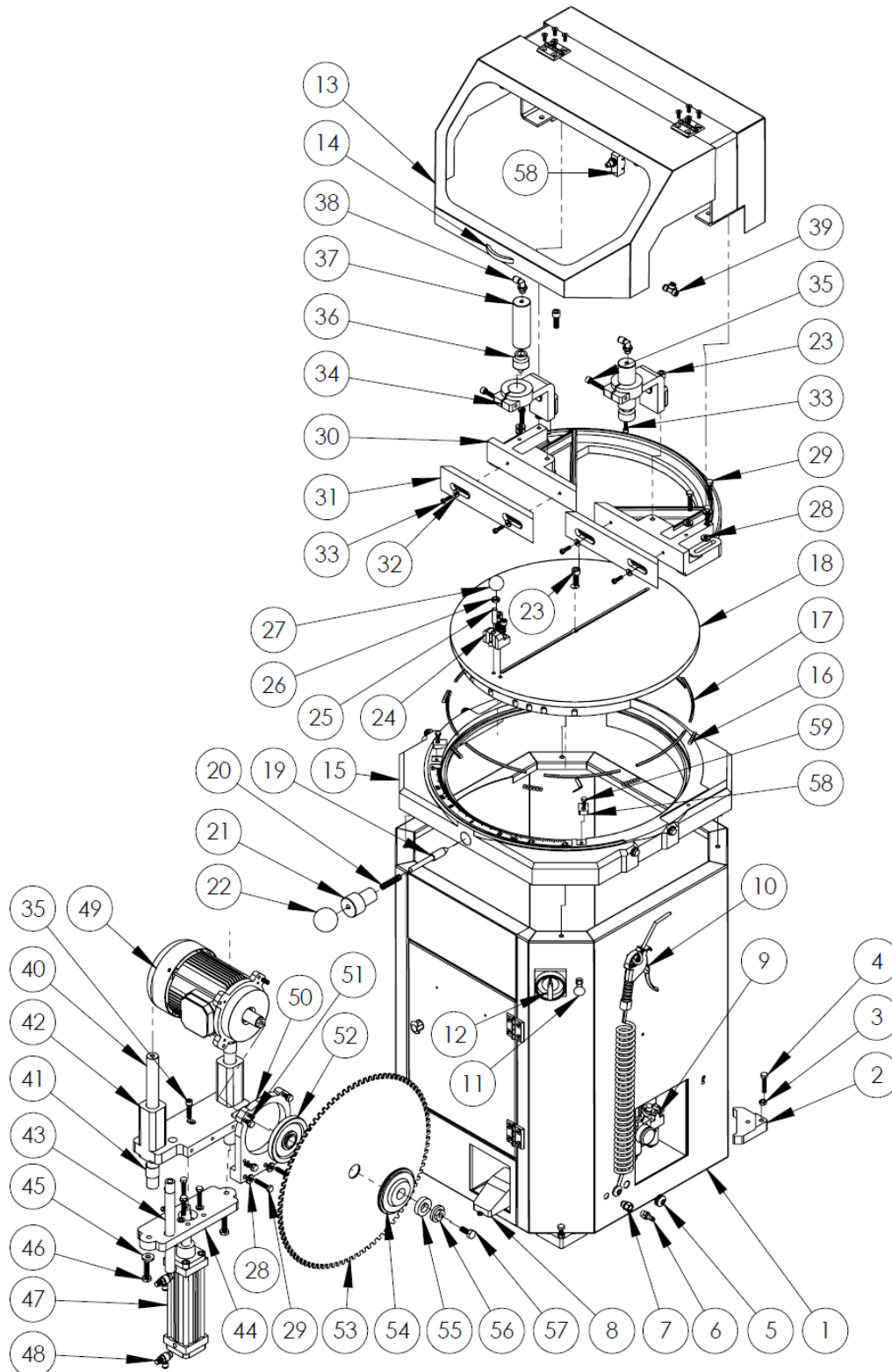

Figure -4a Parts list for the motor and work table components  
SA04-u450ma-1

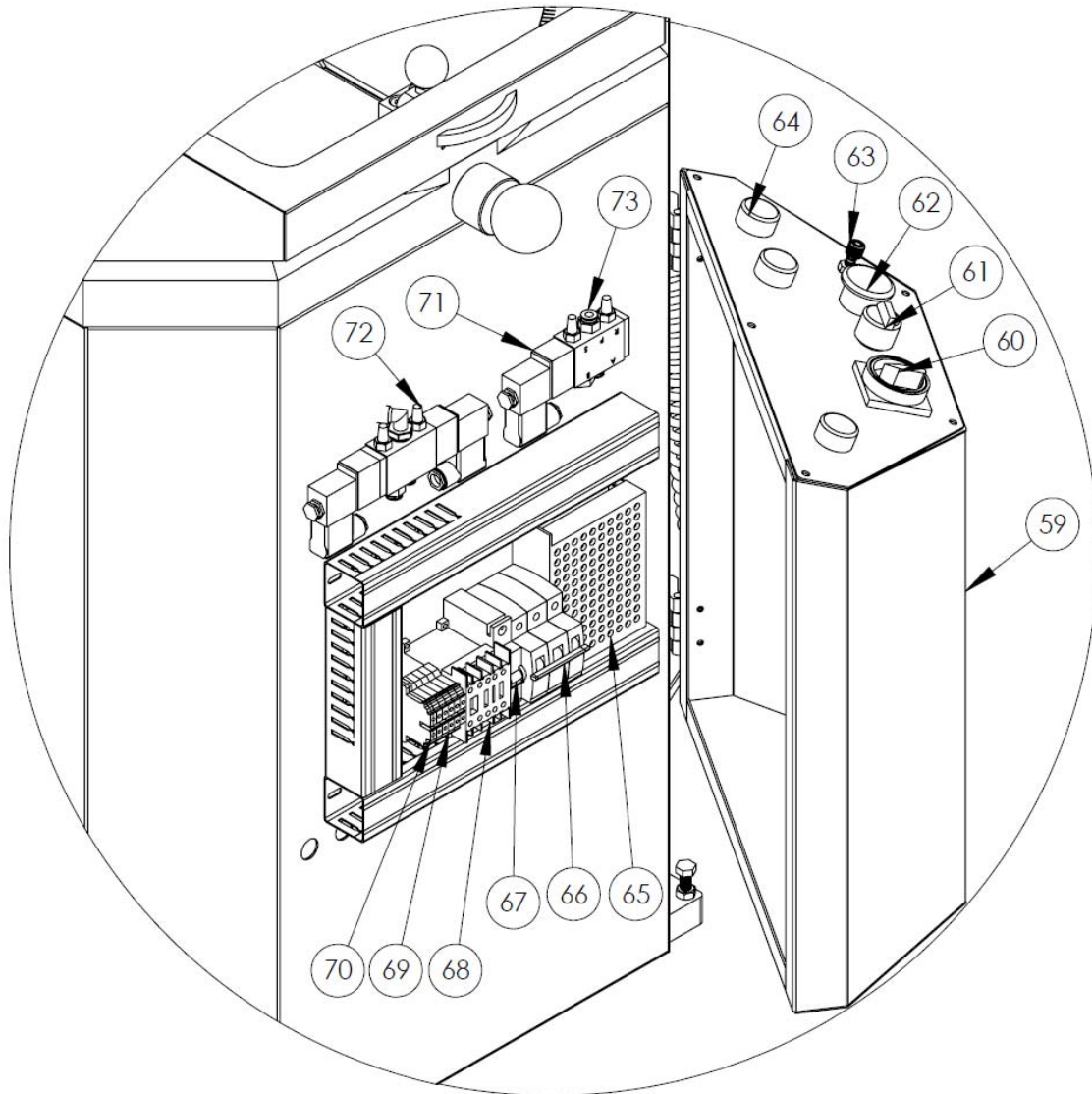

Figure -4b Parts list for the additional components for SA04-u450ma-2

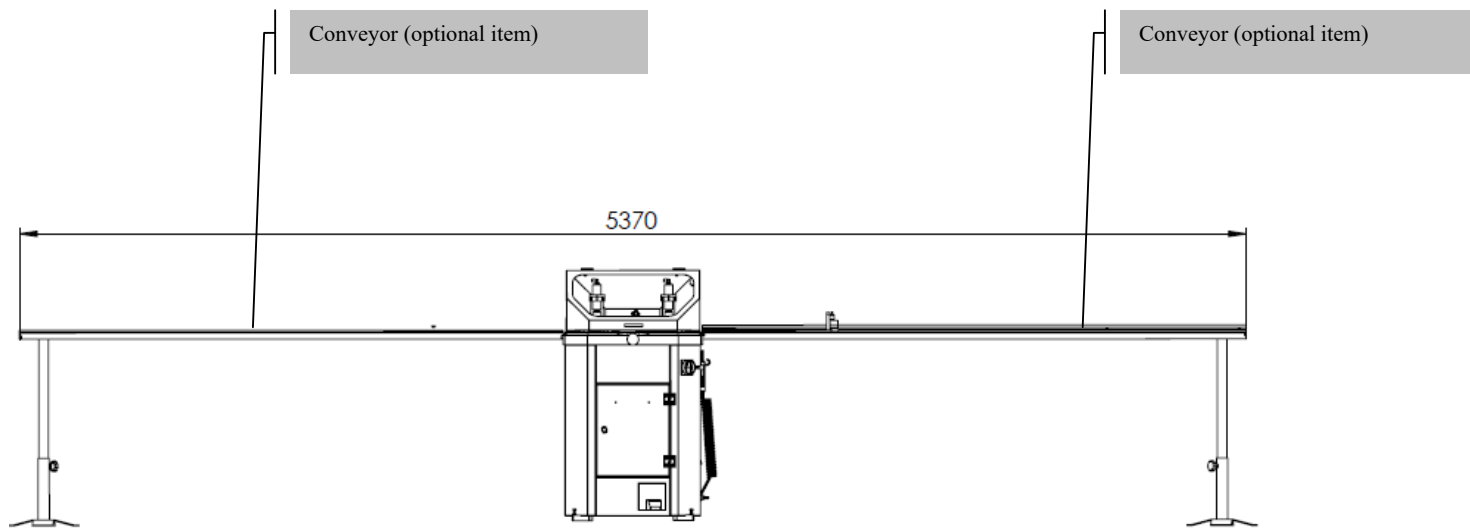

Figure – 6 A Typical conveyor attachments

(Conveyor is an optional feature and the conveyor supplied to you might be also different than this, please check with us about how to connect your conveyor to the machine.)

## 2.6. ELECTRIC AND PNEUMATIC CONTROL PANEL

The electric and pneumatic control panel enables you to make adjustments regarding the air pressure.

The cover of the panel has to be kept closed/locked during cutting.

**Before servicing the machine:**

**TURN OFF THE ELECTRIC AND PNEUMATIC SUPPLY CONNECTIONS.**

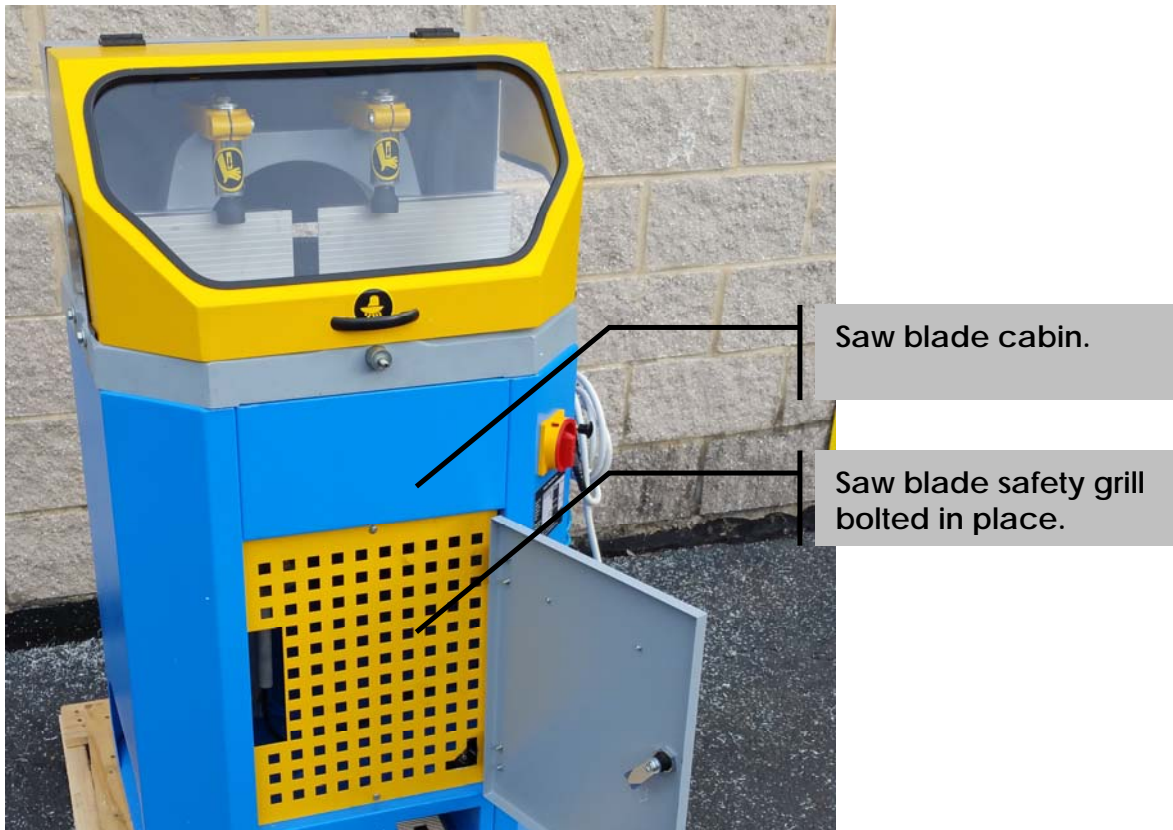

Keep the saw blade safety grill bolted in its place at all times. Remove it only after disconnecting the power from the machine. While working inside the saw blade cabin, DO NOT turn on the power. Personal injury might occur.

## **WARNING:**

**DO NOT** operate the machine if the air pressure is less than 60 psi because the clamps will not safely hold the part you are cutting.

**DO NOT** operate the machine with the top safety cover open.

**DO NOT** disconnect the safety cover switch.

**DO NOT** stick your hand under the safety cover during cutting operations.

**DO NOT** put your hands on the machine work table during cutting operations

The machine motor will not be powered if the top safety cover is open.

The saw blade will not move up if the clamps are not activated.

### 3. SAFETY

#### 3.1. SAFETY INFORMATION

The symbols shown hereunder must be read with a special attention. Not reading or observing them may cause damage to the equipment or personal injury.

**IMPORTANT**

The **IMPORTANT** symbol above shows that it is necessary to pay special attention at the specified operation.

**CAUTION !**

The **CAUTION!** symbol above warns you against specific dangers, and requires reading the text. Not observing may cause damage to the equipment.



**DANGER WARNING**

The **DANGER WARNING** symbol warns you against specific dangers, and you have to read them. Negligence may cause damage to the equipment and bodily injury.

**Read the user's manual carefully before using the machine or carrying out maintenance works.**





## **3.2. ACCIDENT PREVENTION**

**3.2.1.** Our machines are manufactured in accordance with EN 60204-1 and EN 292-2 CE safety directives, which international safety directives.

**3.2.2.** It is the responsibility of the employer to warn his staff against accident risks, to train them on prevention of accidents, to provide the necessary safety equipment and devices for the operator's safety.

**3.2.3.** Before starting to work with the machine, the operator should check the features of this machine; learn all details of the machine's operation.

**3.2.4.** Machine should be operated only by the assigned and properly trained staff members, who have read and understood the contents of this manual.

**3.2.5.** All directives, recommendations and general safety rules contained in this manual have to be observed fully. The machine cannot be operated in any way for purposes other than those described herein. The manufacturer shall not be deemed responsible for any damages or injuries due to wrong/unsafe usage. And such circumstances would lead to the termination of the warranty.

### 3.3. GENERAL SAFETY INFORMATION

3.3.1. The power cable should be placed in a way that nobody can step on it or nothing can be placed on it. Special care must be taken regarding the inlet and outlet sockets.



3.3.2. If the power cable is damaged during operation, don't touch it. Unplug it from the power source. Call your electrician to resolve the problem. Never use damaged power cables.

3.3.3. Don't overload the machine. Your machine will operate more safely with power supply shown on the technical label.

3.3.4. Don't place your hands between parts in motion.



3.3.5. Use protective eye glasses and ear plugs. Don't wear oversize clothes and jewelry. These can be caught by moving parts.



3.3.6. Keep your working place always clean, dry and tidy for accident prevention and safe operation.

3.3.7. Use correct illumination for the safety of the operator. (ISO 8995-89 Standard The Lighting of Indoor Work Systems)

3.3.8. Don't leave anything on the machine.

3.3.9. Don't use any materials other than those recommended by the manufacturer for cutting operations on the machine.

3.3.10. Ensure that the work piece is clamped appropriately by the machine's clamp or vice.

**3.3.11.** Use safe working position, always keep your balance.



**3.3.12.** Keep your machine always clean for safe operation. Follow the instructions at maintenance and replacement of accessories. Check the plug and cable regularly. If damaged, have it replaced by a qualified electrician. Keep handles free from any oil and grease.

**3.3.13.** Unplug first before any maintenance works.

**3.3.14.** Make sure that any keys or adjustment tools are removed before re-operating the machine.

**3.3.15.** If you are required to operate the machine outside, use only appropriate extension cables.

**3.3.16.** Repairs should be done by a qualified technician only. Otherwise, accidents may occur.

**3.3.17.** Before starting a new operation, check the appropriate function of protective devices and tools, make sure that they work properly. All conditions have to be fulfilled to ensure proper operation of your machine. Damaged protective parts and equipment must be replaced or repaired properly (by the manufacturer or dealer).

**3.3.18.** Don't use this machine with improper functioning buttons and switches.

**3.3.19.** Don't keep flammable, combustible liquids and materials next to the machine and electric connections.

#### 4. SAFELY TRANSPORTING THE MACHINE

**IMPORTANT**

The transporting must be done by qualified personnel only.

The machine should be transported by lifting with proper equipment (The machine should not be touching the ground during the transport).

Don't lift the machine before making sure that lifting devices or other equipment is placed properly under the machine.

#### 5. INSTALING THE MACHINE

The machine should be located at least 2 feet (50 cm away) from the back wall for the full opening of the top safety cover to the back, and to do maintenance and cleaning works on the machine.

##### 5.1. PREPARATION

**5.1.1.** The outer dimensions of the machine are shown in the Dimensions page in this manual. The ground where the machine will be placed, should be even and solid enough to bear the weight of the machine. Make sure the machine is leveled. Use the level adjustment bolts on the feet

**5.1.2.** At this up-cut saw, all parts are delivered ready for use.

**5.1.3.** Assemble the optional conveyors, if you received it, to the side of the machine.

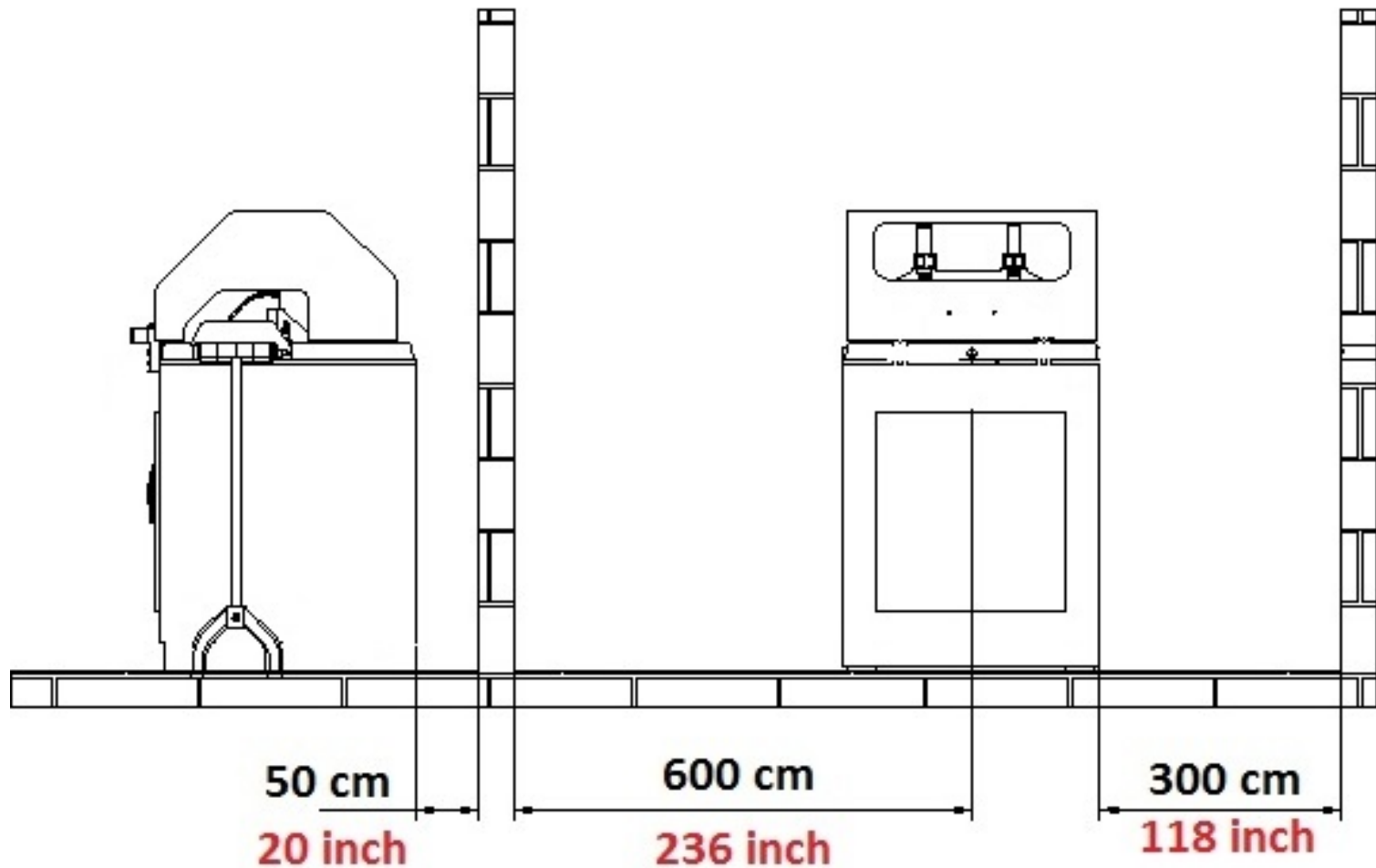
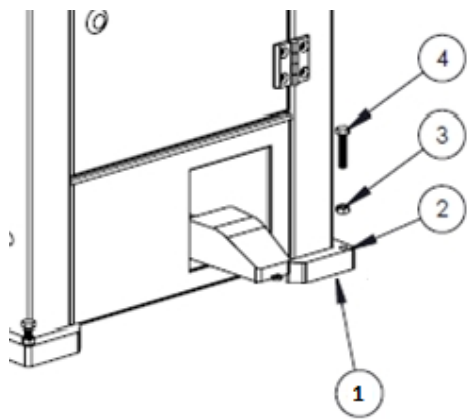
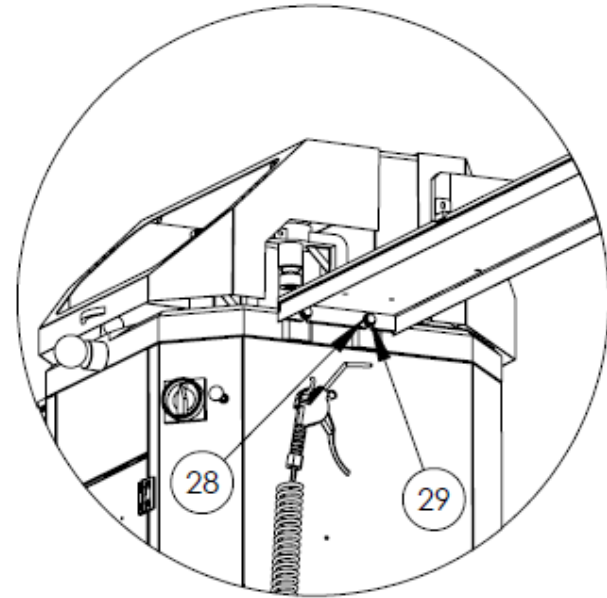

Figure - 7 Typical safe distances around the machine (when installed without the optional conveyor)  
Please add also the conveyor distance if you ordered it.



Make sure the machine is leveled.  
Use the level adjustment bolts on the feet



If your machine came with conveyors, attach them to the machine by using the bolts that came with it.  
Then make the adjustments to level it.

**Figure – 8 Level the machine as needed.**

## 5.2. ELECTRIC CONNECTION

5.2.1. The three-phase power cable socket must be installed by your electrician.

5.2.2. Check the power supply before powering the machine.

5.2.3. Make the electric socket connections when the MAIN POWER SWITCH on the machine is set to 0. (i.e. cut the power going to the machine.)

**CAUTION !**

**\*The power connection must be made by a qualified electrician. The rotation direction of the saw blade must be observed by starting the machine. If the saw blade rotates in reverse direction, the connections must be checked and re-connected properly.**

**\*\*If the saw blade rotates in reverse direction, it will create danger for the operator and the equipment.**

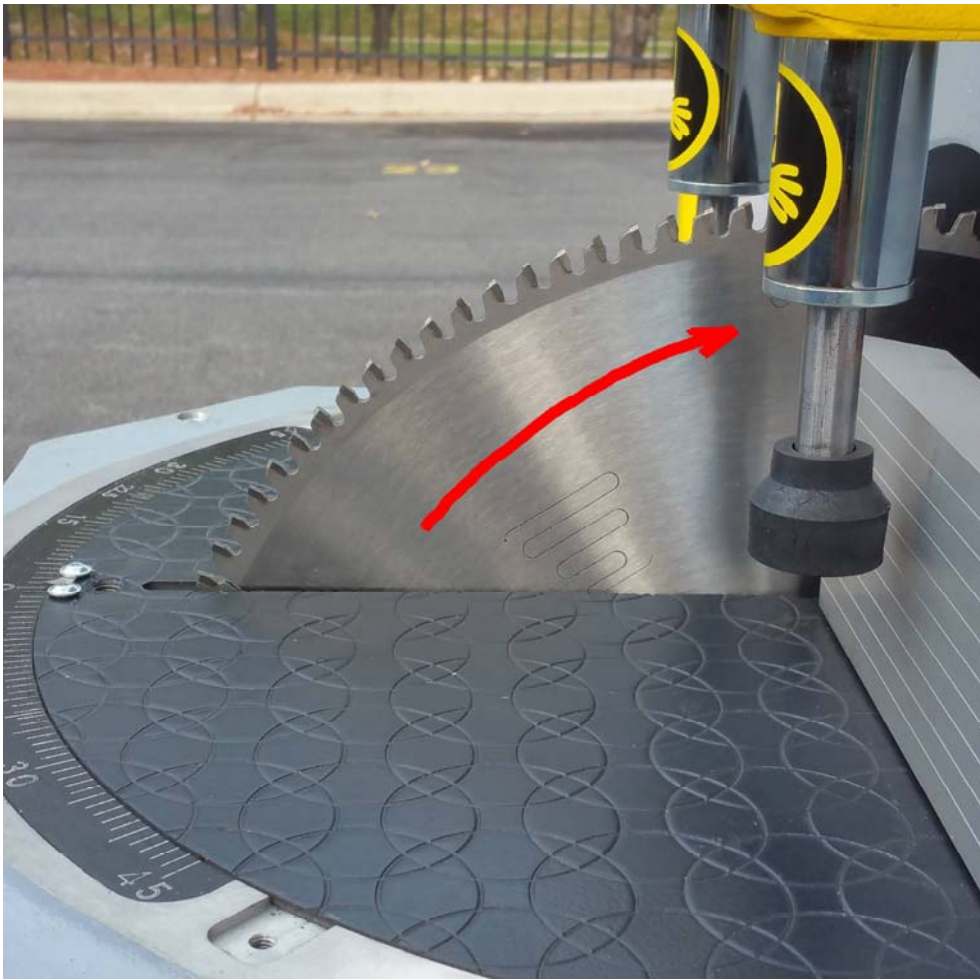

Figure – 9 Saw blade direction must be correct for safe operation.

To correct the rotation direction of the saw blade, connect the machine to an electric power plug for 3-phase, and follow these instructions:

1. Press the Motor Start Button to operate the saw blade.
2. Monitor the rotation direction of the saw blade through the blade slot.
3. The correct direction is shown with an arrow on the picture given on Figure-9.

**The cable connections must be checked and corrected by a qualified electrician.**

**The rotation direction of the saw blade must be determined with testing and checking during installation by a qualified electrician.**



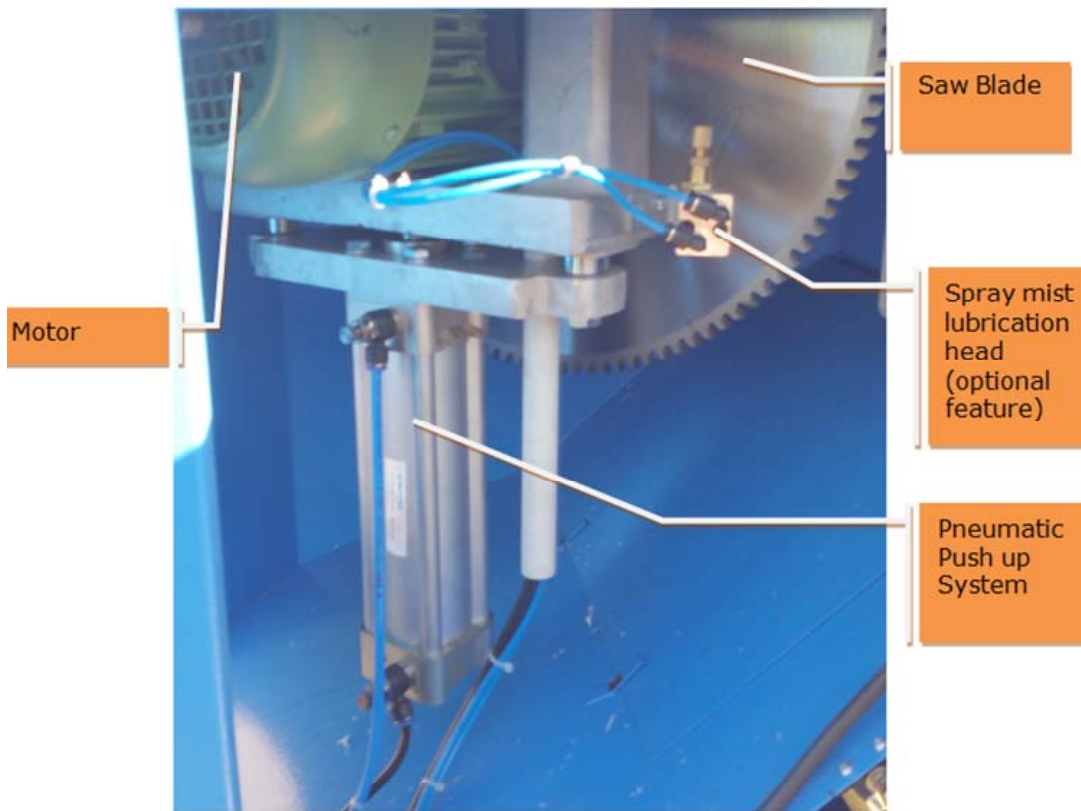

Figure – 10a Pneumatic system of the machine inside cabin.



Adjusting the lowering speed



Adjusting the rising speed

Figure – 10b Speed adjustments. (Before putting your hands inside the saw blade cabin, turn off the power to the machine for safety).



## 6. MACHINE SAFETY INFORMATION

- 6.8.1. It is not allowed to operate the machine with its safety cover and other safety components removed.
- 6.8.2. Your machine operates with 220 V or 400V (440V) ~ 3 Phase 50Hz (60Hz). Use a qualified electrician only for the installation.
- 6.8.3. Lifting, installation, electric, pneumatic maintenance of the machine must be done by qualified personnel only.
- 6.8.4. Routine maintenance and scheduled maintenance should be done by qualified personnel after disconnecting the power and air supply first.
- 6.8.5. Make sure that the machine is cleaned, tested and maintained before starting to operate.
- 6.8.6. Check the safety components, power cable and moving parts regularly. Don't operate the machine before replacing defective safety devices or faulty parts.
- 6.8.7. Never replace the saw blade without disconnecting the power first.
- 6.8.8. Keep foreign materials away from the working area of the machine,
- 6.8.9. Keep away from the machine's moving parts.

### IMPORTANT

The safety data is defined above. In order to prevent any physical damage or damage to the equipment, please read the safety information carefully and keep the user's manual always in an easy accessible place.

## 7. OPERATION

The automatic up-cut saw cuts non-ferrous aluminum, PVC profiles and PVC materials. The operator can adjust (manually via knob) the cutting speed according to the material type by turning the air flow constrictors inside the machine cabin. Inner and outer sharp edges of a carbide tipped circular saw blade ensures high quality clean cutting results.

**CAUTION !**

7.1.1. Start the machine only after properly clamping piece to be cut.

7.1.2. The machine is equipped with vertical clamps. These vertical pneumatic clamps can be adjusted very easily according to the material.



7.1.4. Avoid randomly pressing the buttons on the control panel. If you feel danger during the cutting operation, remove your foot from the foot pedal and turn off the power switch stop button (SA04-u450ma-1 models) or press the emergency button (SA04-u450ma-2 models) immediately, which will terminate the operation.

7.1.5. Close the front door on the main frame and the control panel. Do not remove the safety grill that covers the saw blade cabin. (For safety reasons, the motor will not start unless the top safety cover is closed)

**NOTE: The main frame front door can be opened only during maintenance and cleaning of the machine. During maintenance, cut the power to the machine by switching the MAIN SWITCH to "0" before opening the covers/doors.**

7.1.7. Adjust the cutting angle by using the scale located on the round machine table (0°-15°-22.5°-30°-45°). To turn the round table, release the table locking pin by rotating counter clockwise. Fix the desired (intermediate) angle with the angle adjustment handle. Fix the turning table by tightening the table locking pin (i.e. angle fixer knob) (Figure - 1b).

**CAUTION !**

**NOTE: WHILE CARRYING OUT MITER CUTTING OPERATIONS ON THE MACHINE, MAKE SURE THAT THE CLAMP CYLINDERS AND RIGHT-LEFT MOVING FENCES REMAIN OUTSIDE OF THE CUTTING AREA. (Figure - 11)**



Description of the items on the cutting zone.

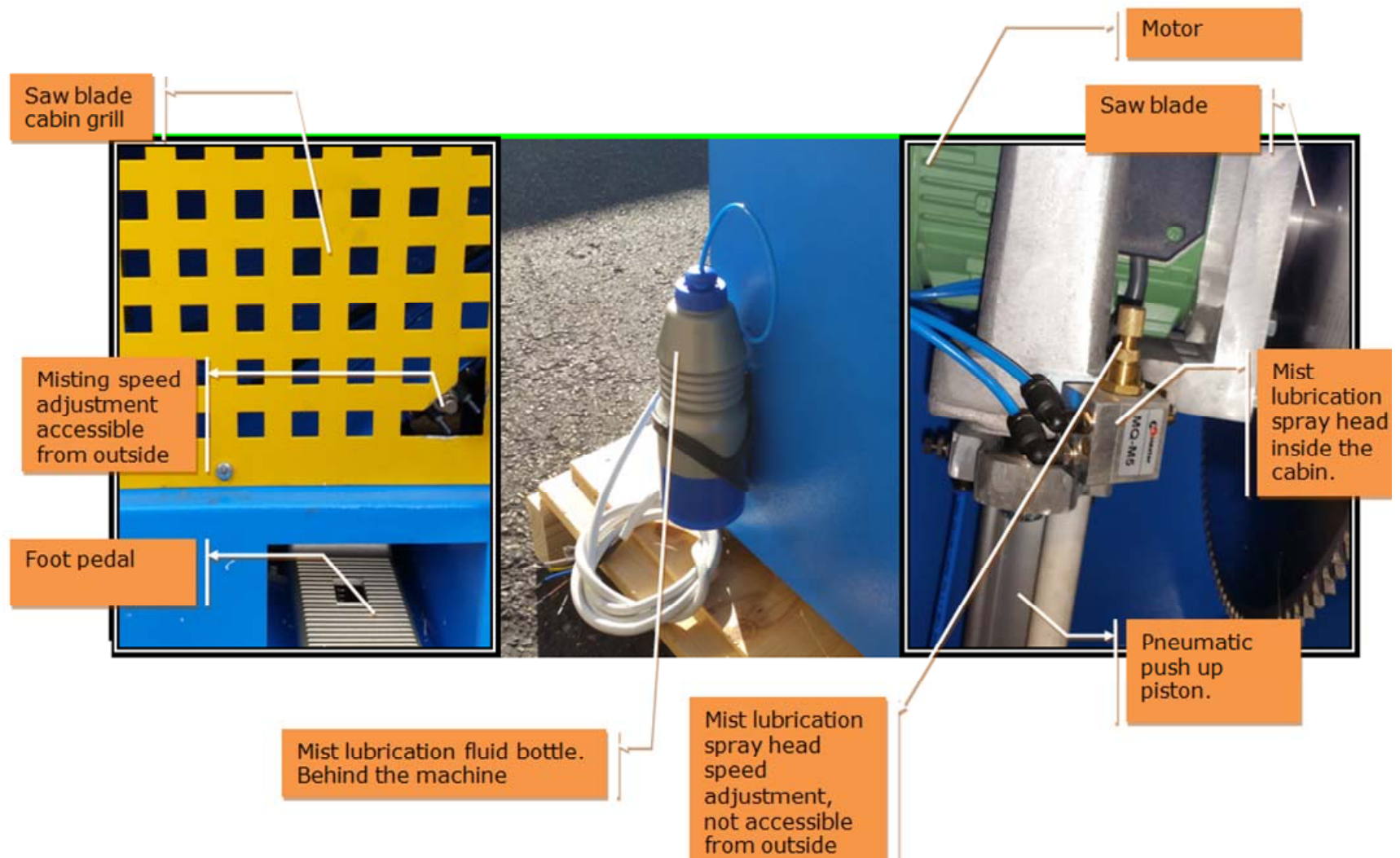

Spray mist lubrication items and their locations on the machine. Spray mist lubrication system is optional and comes only if you order it along with the machine. It is essential to have it for cutting aluminum.

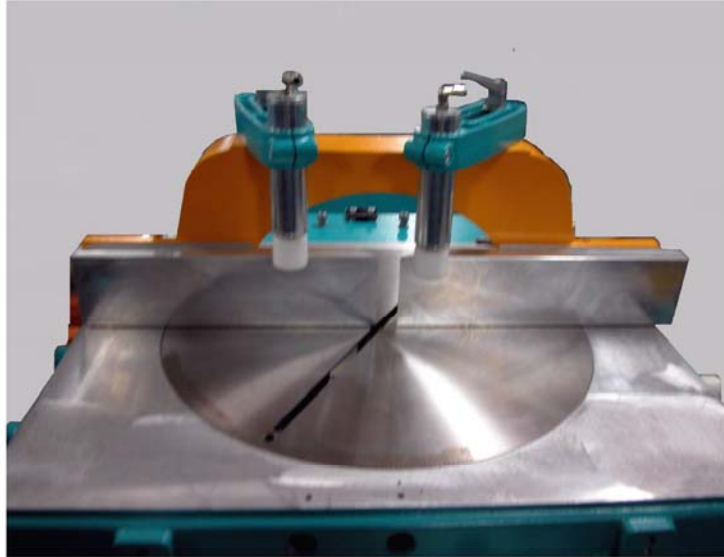

**CORRECT**



**WRONG**

**The clamping cylinders have to be outside of the saw blade's moving area.**

Figure 11 The clamping cylinders must be at a correct position to prevent damage to the cylinders themselves.

**7.1.8.** if you purchased our optional conveyor, adjust the cutting length of the material by using the measuring system with length stop units on the conveyor. After adjusting the cutting length, fix the profile support fence by tightening the stopper on the conveyor.

**7.1.9.** Make sure that the work piece is clamped down by the vertical pneumatic clamps using the clamp activation button on the machine (See Figure - 1b).

**7.1.10.** Start the saw blade by turning on the power switch (SA04-u450ma-1 models) (See Figure - 1b) and pressing the Motor Start Button (SA04-u450ma-2 models).

**7.1.11.** Press foot pedal ((SA04-u450ma-1 models) (See Figure - 1b) or press both Cutting Start Buttons simultaneously (SA04-u450ma-2 models) to move the saw blade.

**7.1.12.** The circular saw blade will rise and cut the material, and then will move down automatically after cutting is complete. It will continue to turn inside the machine cabin until the next cutting.

**7.1.13.** The rising and lowering speed of the saw blade can be adjusted manually (Figure – 10b).

**7.1.14.** Use the clamp button to release the work piece.

**IMPORTANT**

**NOTE:** Adjust the air pressure between 6-8 Bar (90-120 psi). The air pressure is readable from the pressure gauge on the air conditioning unit. If the value on the gauge is less or more than the desired pressure, adjust the pressure between 6-8 Bar by turning the air pressure adjustment knob to the right or to the left as needed. (Figure – 12)

**If the air pressure drops below 4 Bar (90 psi), do not use the machine for safety. Remedy the situation before you continue.**

**7.1.15.** The conditioner unit collects the water from the air inside its cup in order to prevent damage to the pneumatic system components. Discharge this water periodically (at the end of each working day) by pressing or opening the button under the conditioner.

## **7.2. ADJUSTING THE AIR PRESSURE**

**7.2.1.** Pull the adjustment knob of the conditioner upwards. (See Figure – 12)

**a-** Turn the knob in clockwise direction to increase the pressure

**b-** Turn the knob in counter clockwise direction to decrease the pressure

**7.2.2.** Once you read 6-8 Bar (90-120 psi) on the gauge, push the knob down and lock it in that position. See Figure - 12

**7.1.3.** The manufacturer recommends the following oils for the air conditioning unit:  
TELLUS C 10  
BP ENERGOL HLP 10  
MOBIL DTE LIGHT  
Any brand of airtool oil.  
Any brand Number 10 machine oil.



Air connection location.



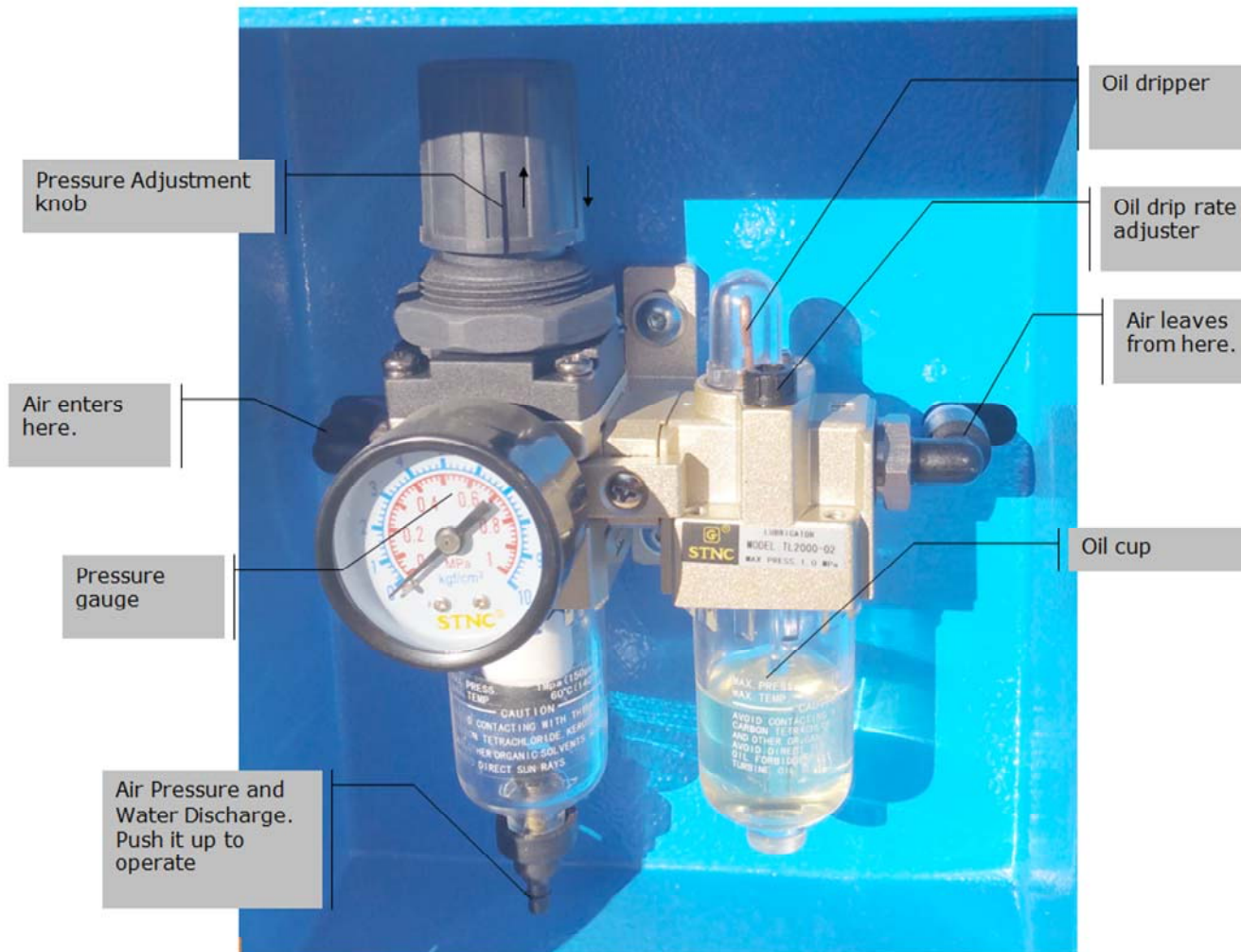

Figure - 12 Air conditioning Unit.

### **7.3. CHECKING ANGLE ADJUSTMENT OF SAW BLADE AND BRIDGE**

If you run into any problem during cutting operation (i.e. miter cutting)

**7.3.1.** Perform a visual control on the saw blade, if possible with the help of a dial gauge.

**7.3.3.** If the problem occurs during miter cutting, check the perpendicularity of the saw blade with the help of a quick square tool. If the perpendicularity is not correct, loosen the screw which tightens the angle adjustment pin. Turn the rotating round table so that the perpendicularity can be achieved and then fix position of the adjustment pin by tightening its screw.

## **8. SAFE INSTALLATION OF THE SAW BLADE**

**8.1** Follow the instructions below to remove the circular saw blade from the blade shaft.

**8.1.1.** Switch the MAIN POWER SWITCH on the machine to "0" to cut the power coming to the machine. Disconnect the power from the wall receptacle as an added precaution. Open the front cover of the main frame, and then remove the protection grill.

**8.1.4.** Hold the saw blade shaft at the opposite end with a wrench key and prevent the motor shaft from turning. (Figure – 14)

**8.1.5.** Remove the bolt from the center of the saw blade, the washer, outer nut washer and the saw blade bracket in an order. (See Figure – 15)

**8.1.6.** Remove the saw blade carefully.

**8.1.7.** Insert the new saw blade on the saw blade shaft, ensuring correct rotation direction. (See Figure – 9)

**8.1.8.** Insert the other parts (washer, outer nut washer and saw blade bracket ) in reverse order as removal.

**8.1.9.** Tighten the bolt in center of the saw blade by turning in clockwise direction. (Prevent the saw blade shaft from turning by holding it with a wrench .)

**8.1.10.** It is necessary to sharpen / replace the saw blade in certain intervals depending on the material. If the cut material leaves burr after the cutting operation or if the saw blade is strained, it needs to be sharpened / replaced.

**CAUTION !**

**8.1.7** The arbor diameter is 32 mm for the saw blade. see Figure – 15.

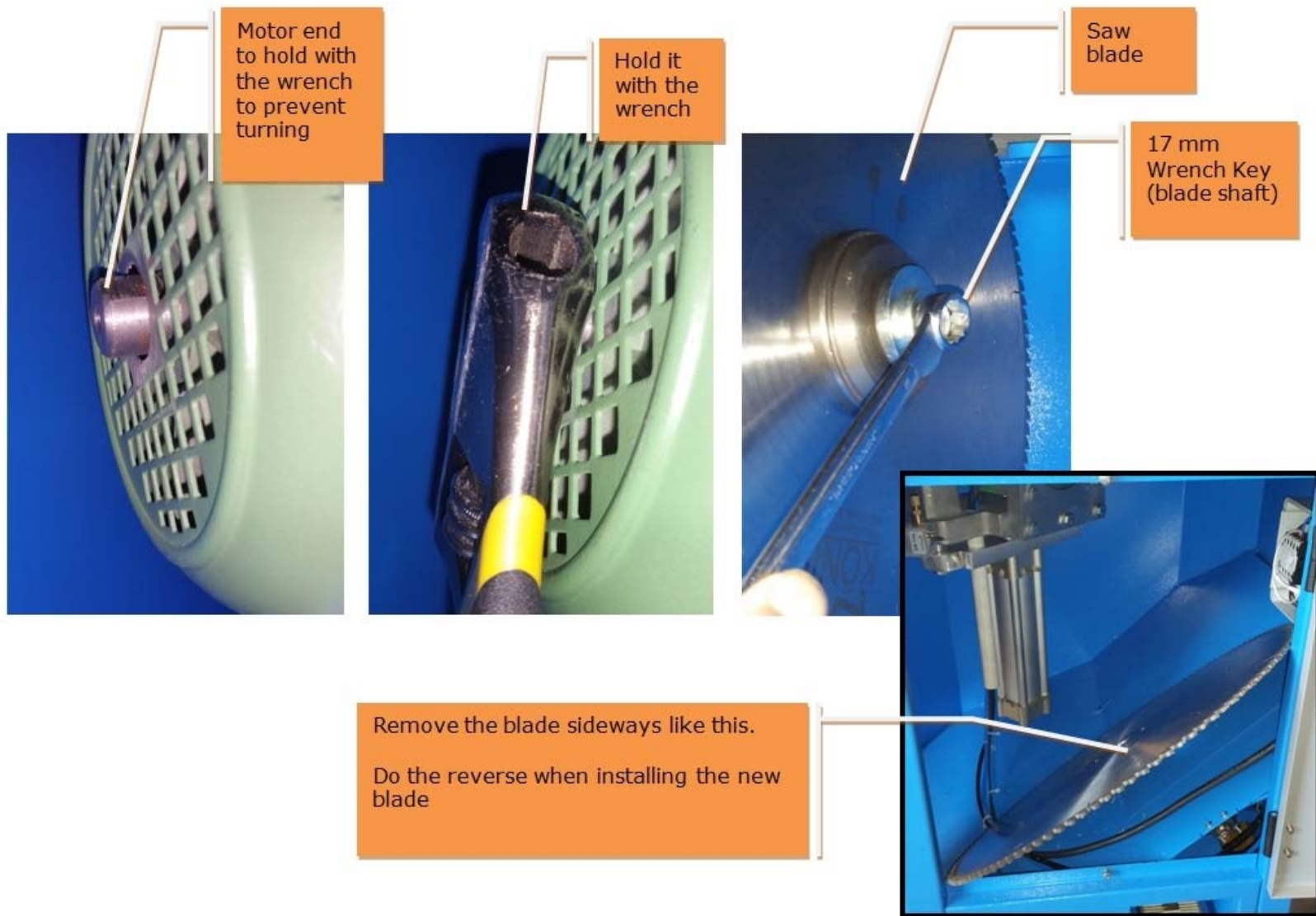

Figure - 14 Saw Blade Changing Steps.

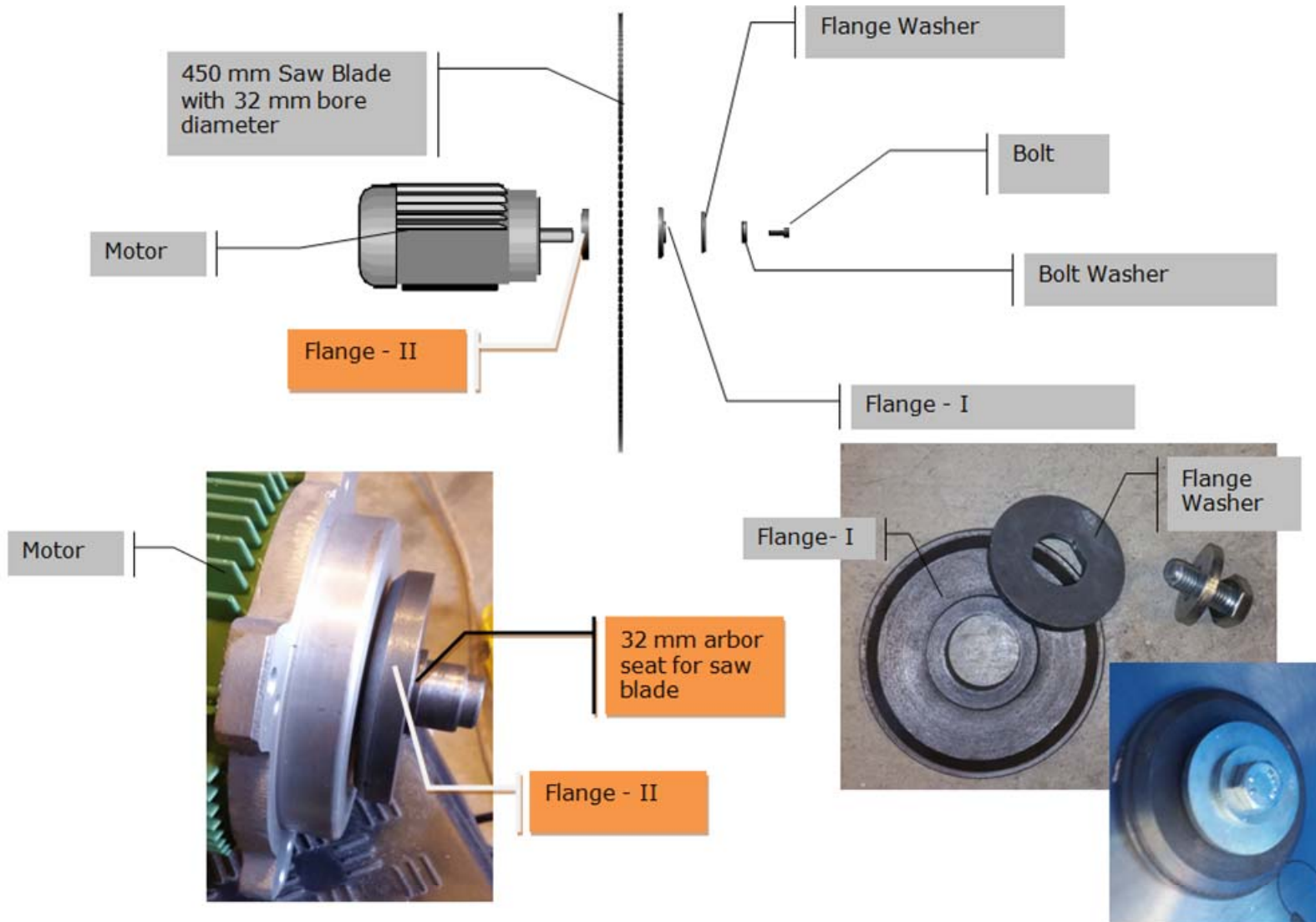

Figure – 15 Saw Blade and Nuts assembly.

## 9. MAINTENANCE

### 9.1. ROUTINE CONTROLS and MAINTENANCE

#### 9.1.1 BEGINNING THE WORK

9.1.1. Make sure that the worktable of the machine and all parts are clean and dry. Degrease and dry the table. Especially make sure that the holding grips are clean and dry.

9.1.2. Remove all burr, chips and foreign materials from all surfaces of the machine. Use protective eye goggles.



9.1.3. Check the saw blade before each use. Turn the saw blade carefully (after removing the blade guard) to see the teeth of the saw blade. Replace the saw blade if it is damaged.



9.1.4. Check the pressure of the air pressure system. If necessary, adjust the air pressure between 6-8 Bar (90 to 120 psi). (See section 7.2 for more information.)

9.1.5. Check the air pressure filters and the oil level in the conditioner jar. Fill it up if the oil level is low. (See section 7.2) **Unplug and disconnect the air pressure connections first, before carrying out this work.**

## **9.2. MAINTENANCE AT THE END OF THE WORKING DAY**

**9.2.1.** Disconnect electric power and air power. (Main Power Switch must be on "0" position)

**9.2.2.** Remove all burr, chip and foreign materials from the machine surfaces. If it is necessary to clean the inside of the blade guard, remove the front cover, use gloves to protect your hands from the sharp edges of the blade.

**9.2.3.** If water or water based cooling liquids are used during cutting, dry the machine with a dry cloth after the operation is finished.

**9.2.4.** Apply a thin layer of machine oil to protect the table against corrosion. If the machine will not be used for a long time, lubricate it with a protective oil.

**9.2.5.** Don't use paint damaging materials/liquids for cleaning the machine.

**9.2.6.** Lubricate both surfaces of the saw blade with machine oil in order to protect it against corrosion.

## 10. TROUBLESHOOTING GUIDE

Here are some recommendations for solving urgent problems. If the trouble cannot be solved, or if you have a problem other than those described hereunder, please contact our technical service or your nearest dealer.

TROUBLE	CAUSES	REMEDY
Low cut surface quality (at aluminum and similar materials): <ul style="list-style-type: none"> <li>• Rough surface</li> <li>• Large chips/shavings</li> <li>• Non-homogenous surface</li> <li>• Saw blade traces are visible.</li> </ul>	Saw blade surfaces are not cooled as needed.	<ul style="list-style-type: none"> <li>• Lubricate the saw blade cutting surfaces.</li> <li>• Use cooling liquid.</li> </ul>
	Damaged or blunt saw blade.	Check the saw blade teeth. Replace if necessary.
	Saw blade is moving up too fast.	The saw blade rising speed is too high for the material. Decrease it.
Motor does not work when Start button is pressed or when the power switch is turned on.	<ul style="list-style-type: none"> <li>• No power supply to the machine.</li> <li>• Main Power Switch is in "0" position.</li> <li>• The upper safety cover is open.</li> <li>• Top safety cover safety switch a is faulty.</li> </ul>	<ul style="list-style-type: none"> <li>• Check the electric cable connections.</li> <li>• Check the electric power sockets. Switch the Main Power Switch to "I".</li> <li>• Close the top safety cover.</li> <li>• Replace the safety switch.</li> </ul>
Motor is working but the pneumatic clamp pistons do not work.	There is no air supply to the machine or the air pressure is low.	<ul style="list-style-type: none"> <li>• Check the air compressor connections.</li> <li>• Adjust the air pressure between 6-8 Bar (90-120 psi) on the conditioner.</li> </ul>
The saw blade rotates in reverse direction.	The electric connection, at the power cable or the connection at the electric panel is wrong.	Call a qualified electrician to fix the problem.
Motor works but the saw blade is not rising upward.	The material is not clamped down.	Clamp the material first, then try again.



12. WIRING DIAGRAMS

ELECTRICAL DIAGRAM FOR SA04-u450ma-1 model

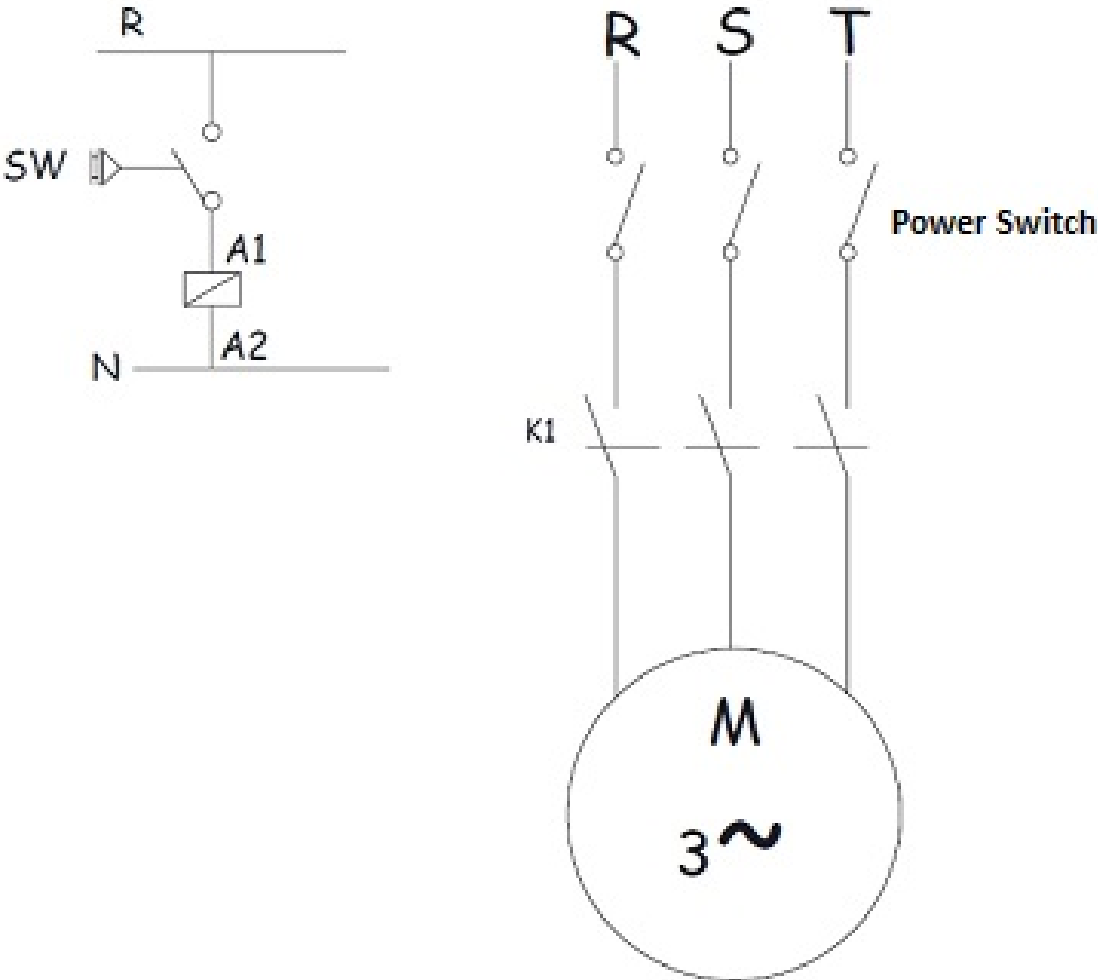

PNEUMATIC DIAGRAM FOR SA04-u450ma-1 model

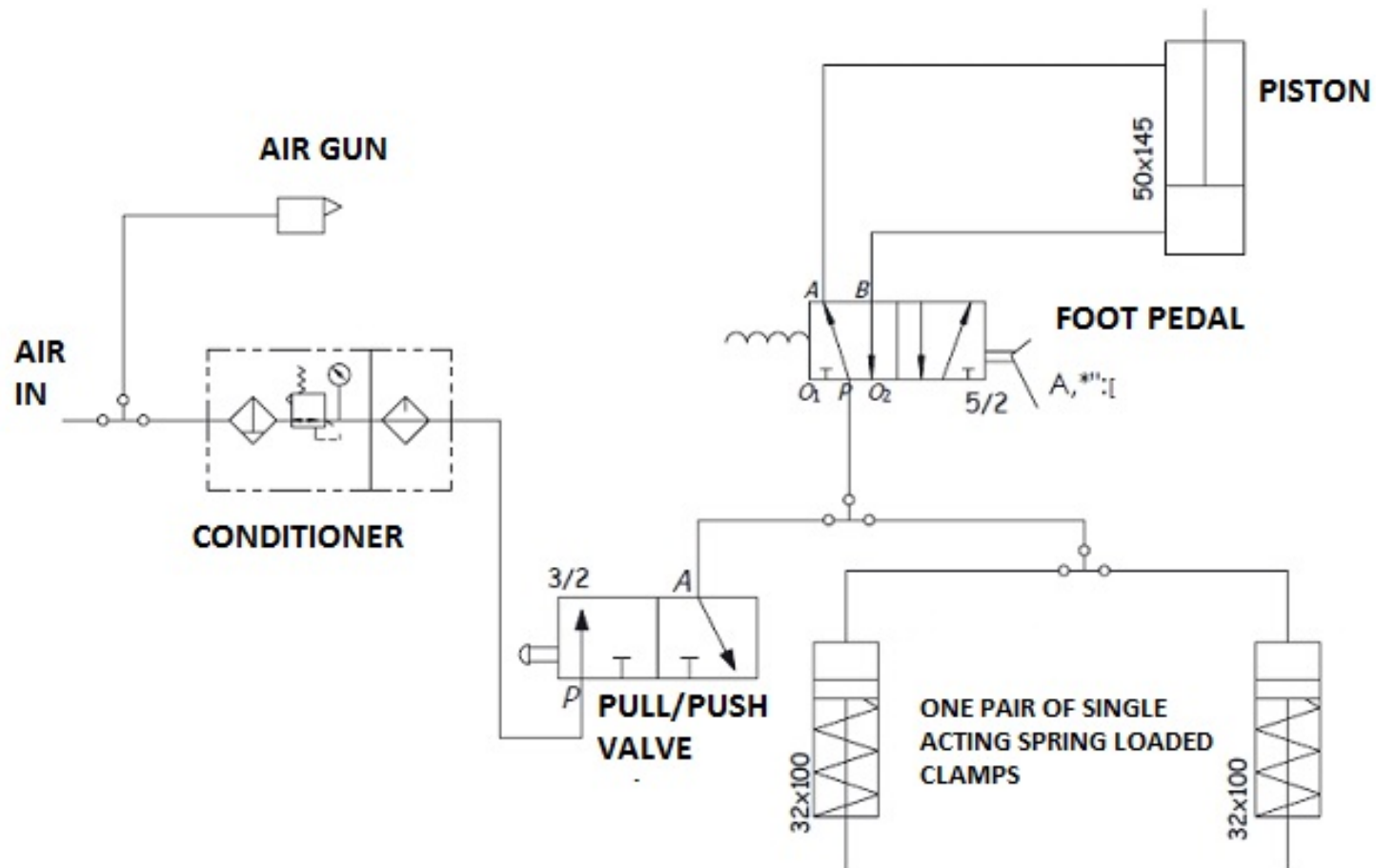



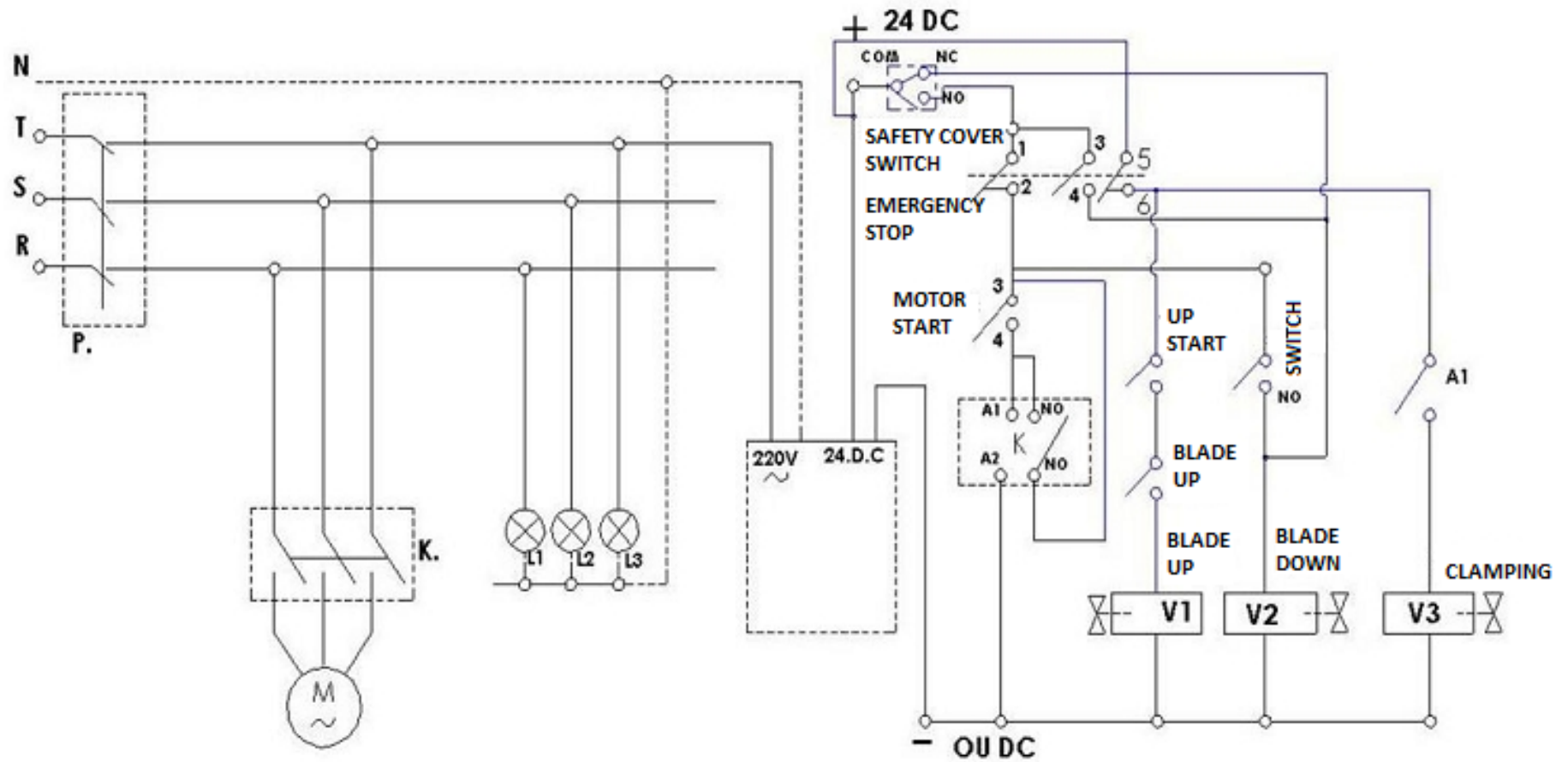

ELECTRIC AND PNEUMATIC DIAGRAM FOR SA04-u450ma-2 model

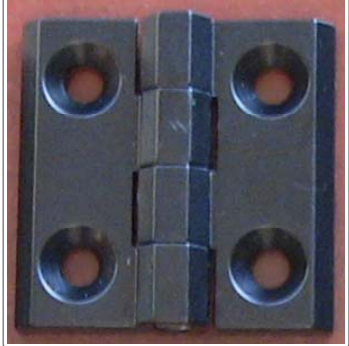

### 13. PICTORIAL GUIDE TO USE WHEN ORDERING PARTS FOR THIS MACHINE

We are providing this pictorial guide to help you out when ordering spare parts for this machine. This pictorial guide does not include all parts. For the parts that do not exist here, please refer to the component list provided in the previous pages or call us.

Row #	Part	Picture	Stock Code
1	Hinge for the top safety cover.		
2	Main Power Switch		
3	Saw blade		<p>450 x 4.0x32z120 N. Alu 450 mm diameter, 32 mm arbor size. 120 teeth, Negative Teeth for Aluminum Good for cutting aluminum and PVC (vinyl)</p>

	Clamp piston.	 A close-up photograph of a clamp piston assembly. The top part is a yellow metal housing with a silver-colored piston rod extending downwards. The piston rod has a black rubber seal at its base. A yellow and black warning label is visible on the silver part. The assembly is mounted on a white surface.	
	Clamp piston holder.	 A close-up photograph of a yellow metal clamp piston holder. It is a rectangular block with several slots. A blue hydraulic hose is connected to a silver-colored fitting on top. The holder is mounted on a grey surface.	

