

CLAUSING 10" precision lathes

*12 speeds – 52 to 1700 rpm

*1 1/16" hole thru spindle

*Flame hardened bed ways

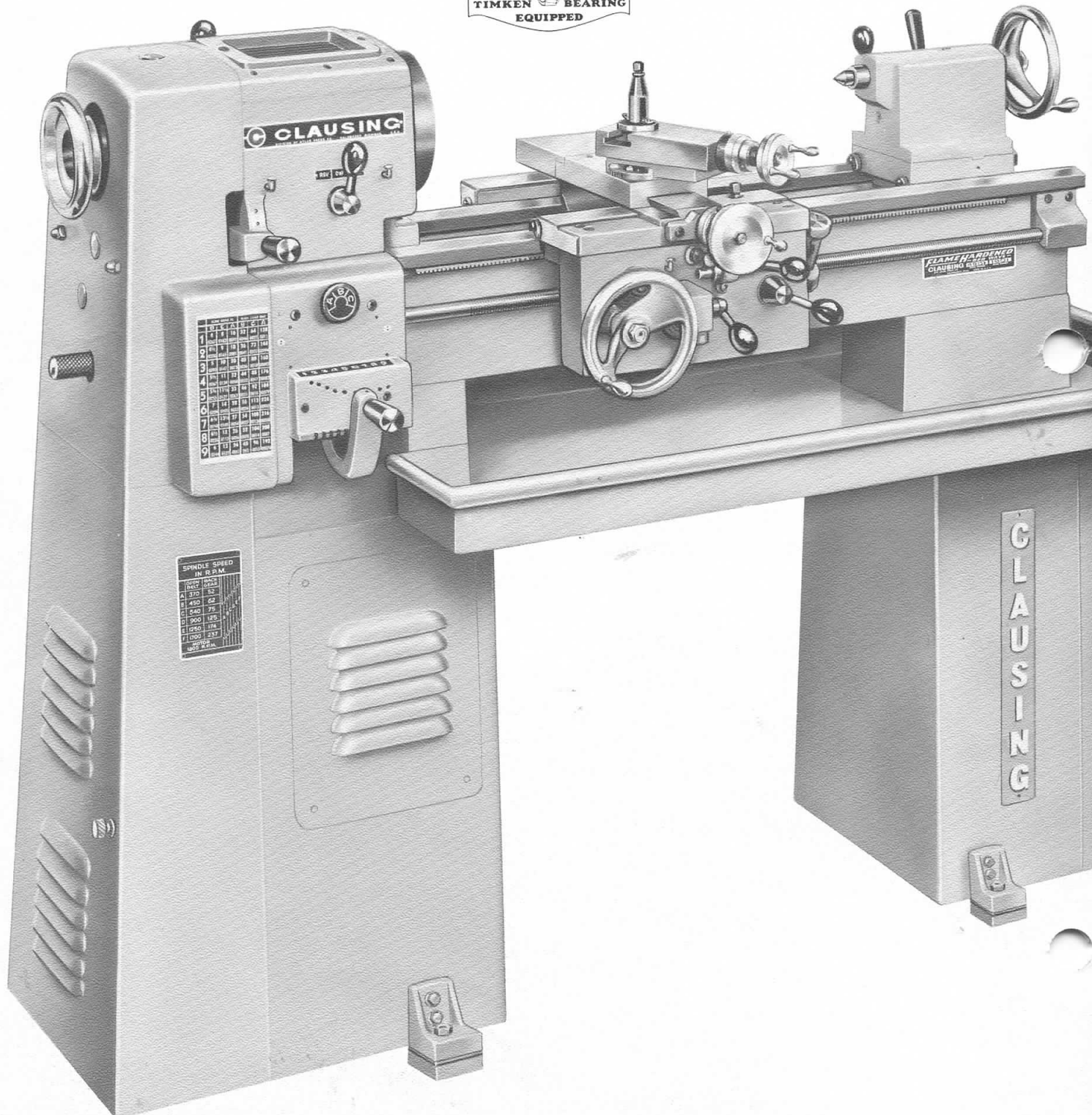

SPINDLE SPEED IN R.P.M.	
1	52
2	63
3	75
4	90
5	108
6	128
7	150
8	177
9	210
10	252
11	306
12	360

CLAUSING

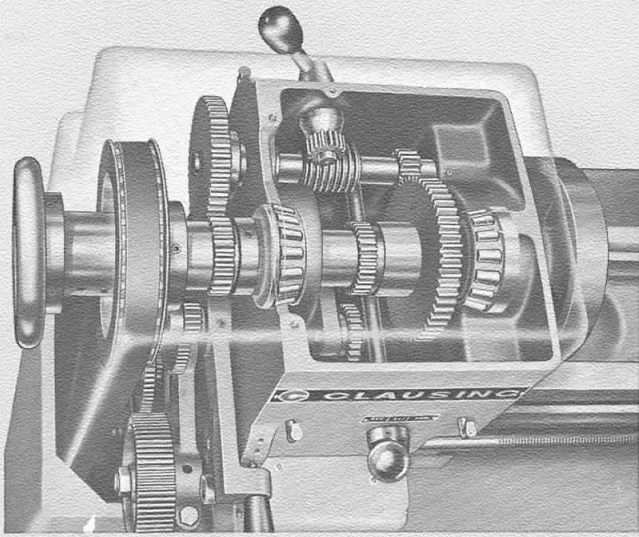

ENCLOSED HEADSTOCK—1-1/16" SPINDLE HOLE

Rigid box-type headstock—a precision housing—is hand fitted to bed ways. Headstock is enclosed—all controls, including those for back gears, are outside for safe, efficient operation. And, switch lever is interlocked to prevent engagement of back gears while lathe is running, or accidental reversing of spindle.

Forged spindle is chrome-moly steel. Has hardened nose, ground threads—turns on Timken tapered roller bearings. Spindle has 1-1/16" bore—larger thru-spindle work capacity.

BALL BEARING QUICK-CHANGE provides 54 feeds and threads (including 11½ and 27) without change of gear train. Stack gear shaft and lead screw turn on lubricated-for-life ball bearings.

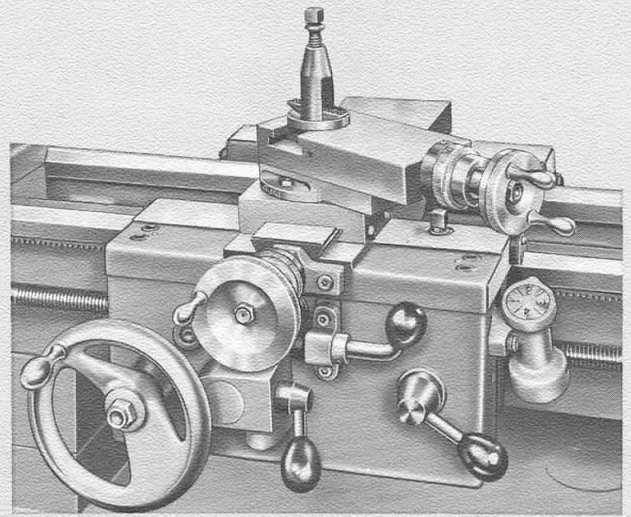

CARRIAGE, POWER FEEDS

The husky carriage is engineered to take full advantage of Clausing's wider work range.

Hand fitted saddle bears a full 11-inches on bed ways. Wide, deep bridge provides a rigid support for the cutting tool.

Power feed gear shafts in apron are supported at both ends. Feeds are engaged thru fast-acting positive clutches—lead screw threads are used for thread cutting only. Indicator dial, furnished, simplifies threading. Feed screws have Acme threads, large micrometer graduated dials.

Safety clutch in apron and shear pin in lead screw protect against overload. Safety-interlock prevents engaging half nuts and longitudinal feed at same time.

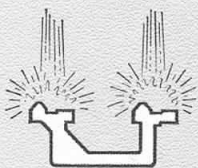

**FLAME HARDENED
BED WAYS**

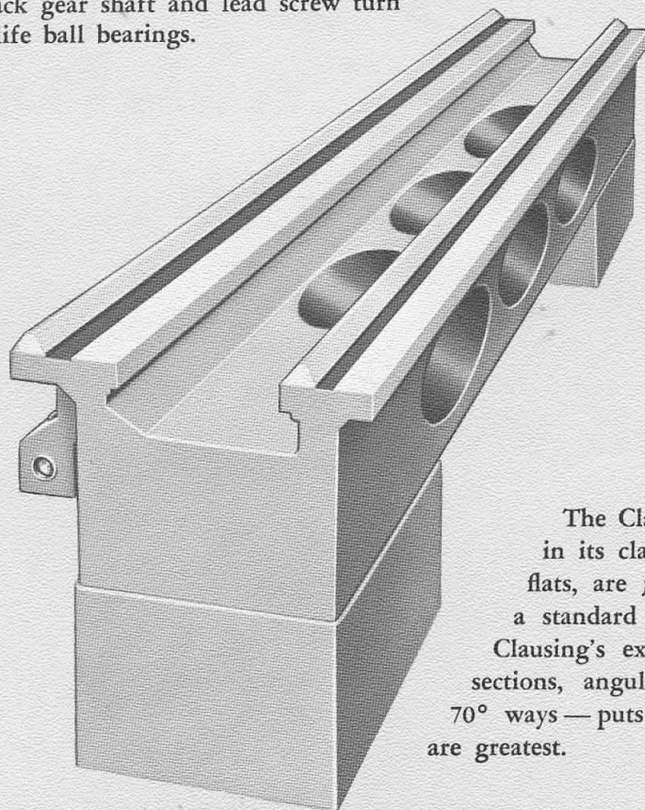

ELLIPTICALLY BRACED PORTED BED

The Clausing lathe bed is the largest and heaviest in its class. And, all four ways, two V's and two flats, are *flame hardened* and precision ground—a standard feature that adds years to accuracy life. Clausing's exclusive bed design—with solid box end sections, angular way supports, elliptical bracing, and 70° ways—puts maximum strength where turning forces are greatest.

Cog belt, cog pulleys drive spindle — greater efficiency — more power — smoother operation

Tooth grip, not friction, transmits power from countershaft to spindle — teeth in belt mesh with teeth in pulleys — belt load on spindles and bearings is at a minimum.

Countershaft and spindle drive pulley turn on heavy-duty lubricated-for-life ball bearings. All pulleys are accurately machined, and entire drive is dynamically balanced after motor is installed.

This modern drive permits you to take full advantage of Clausing's superior construction and capacity — power for heavy cuts, smoothness for close tolerances, speeds for top efficiency with today's metals and tools.

UNIT ENGINEERED—ANOTHER CLAUSING EXCLUSIVE

The headstock, bed and pedestal are designed to form an integral unit — basic to Clausing's greater rigidity, capacity, accuracy and superior performance.

Pedestals are $\frac{1}{4}$ " steel plate with welded reinforcements. Tailstock pedestal has storage shelves.

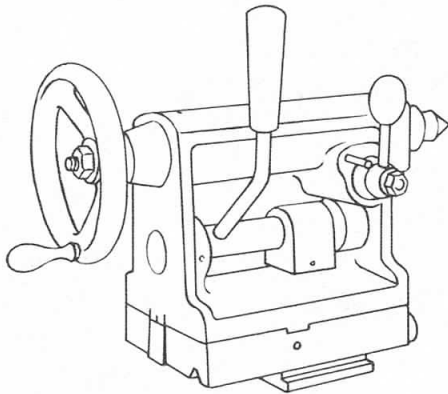

**CAM-LOCK
TAILSTOCK**

A 28-pound work support, hand fitted to the bed ways.

Quick to position, quick to lock — one movement of the lever anchors tailstock to bed or releases it — no wrenches.

Has $\frac{3}{4}$ " set-over for taper work. Ram is graduated 0 to $2\frac{1}{2}$ " by 16ths.

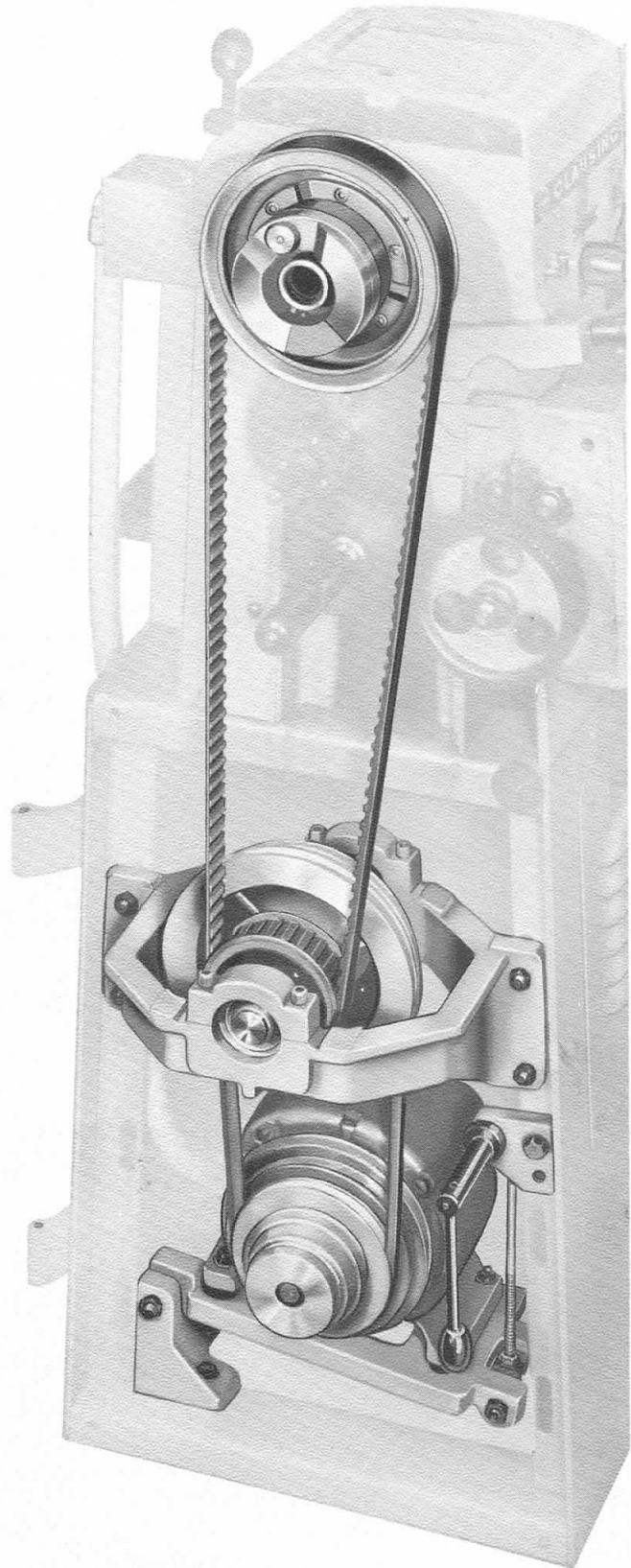

rpm

ys

CLAUSING

SPECIFICATIONS

Make any comparison—specification for specification, feature for feature—the Clausing 10 offers more PLUS VALUE than any lathe in its class.

CAPACITIES

Swing over bed and saddle wings 10 $\frac{1}{8}$ "
 Swing over cross slide..... 5 $\frac{1}{2}$ "
 Hole through spindle 1 $\frac{1}{16}$ "
 Collet capacity—spindle nose type 1"
 Collet capacity—draw-bar type $\frac{3}{4}$ "
 Distance between centers 24", 36"

SPINDLE SPEEDS

Number 12
 Direct drive 370, 450, 540, 900, 1250, 1700 rpm
 Back gear drive 52, 62, 75, 125, 174, 237 rpm

THREADS AND FEEDS

Number, threads and feeds 54
 Longitudinal feed range00065" to .0367"
 Cross feed range00016" to .00917"
 Thread range, Standard right or left 4 to 224
 Screw threads per inch . . . 4, 4 $\frac{1}{2}$, 5, 5 $\frac{1}{2}$, 5 $\frac{3}{4}$, 6, 6 $\frac{1}{2}$, 6 $\frac{3}{4}$,
 7, 8, 9, 10, 11, 11 $\frac{1}{2}$, 12, 13, 13 $\frac{1}{2}$, 14, 16, 18, 20, 22,
 23, 24, 26, 27, 28, 32, 36, 40, 44, 46, 48, 52, 54, 56,
 64, 72, 80, 88, 92, 96, 104, 108, 112, 128, 144, 160,
 176, 184, 192, 208, 216, 224
 Lead screw $\frac{3}{4}$ " dia., 8 Acme t.p.i.

HEADSTOCK

Hole through spindle 1 $\frac{1}{16}$ "
 Spindle nose hardened, ground threads, 1 $\frac{3}{4}$ "-8
 Spindle nose internal taper 4 M.T.
 Spindle center 2 M.T.
 Spindle bearings two Timken tapered roller

BED

Flame-hardened ways two 70° V-ways, two flat ways
 Depth 5 $\frac{7}{8}$ "
 Width 7 $\frac{3}{8}$ "
 Length 44", 56"

CARRIAGE

Length on bed 11"
 Width of bridge 3 $\frac{3}{4}$ "
 Cross slide travel 7 $\frac{1}{2}$ "
 Compound rest graduated 0-90° left and right
 Compound rest travel 2 $\frac{1}{2}$ "
 Tool post takes $\frac{3}{8}$ " tool bits or holder for $\frac{1}{4}$ " bit

TAILSTOCK

Spindle center 2 M.T.
 Spindle diameter 1 $\frac{1}{8}$ "
 Spindle travel 2 $\frac{3}{4}$ "
 Spindle graduated 0-2 $\frac{1}{2}$ " by 16ths
 Set-over $\frac{3}{4}$ "

DRIVE

Drive to countershaft 5-step pulleys, V-belt
 Drive to spindle positive-grip timing belt
 Motor, 1725 rpm furnished $\frac{3}{4}$ or 1 HP, optional
 Reversing switch furnished across-the-line drum
 (Note: Motor and switch are installed and factory tested.)

STANDARD EQUIPMENT, all models: flame-hardened bed ways, chip and coolant pan, motor, reversing switch, 6" face plate, two centers, center sleeve, tool post, threading dial, wrenches and instruction book. (Design and specifications are subject to change without notice.)

10" LATHES			
Model Number	Between Centers	Motor Furnished (specify voltage)	Ship. Wt.
4901	24"	$\frac{3}{4}$ hp, single phase	845
4902	24"	$\frac{3}{4}$ hp, three phase	845
4903	24"	1 hp, single phase	860
4904	24"	1 hp, three phase	860
4911	36"	$\frac{3}{4}$ hp, single phase	900
4912	36"	$\frac{3}{4}$ hp, three phase	900
4913	36"	1 hp, single phase	915
4914	36"	1 hp, three phase	915

Single-phase motors are capacitor start, 115/230V, 60C. Three-phase motors — 208/220/440V, 60C*. All motors ball bearing equipped. *Operate on 50 Cycle at 1425 rpm.

OPTIONAL ELECTRICAL EQUIPMENT

For Factory Installation Only

(Controls for field installation—price on application.)

No. 7030 MAGNETIC STARTER, for 3 phase*, with Drum Reversing Control. Protects motor against overload, low and no voltage. Motor will not automatically restart when power is restored—drum control† has momentary contactors.

No. 7032 MAGNETIC REVERSING STARTER, for 3 phase*, WITH 110 VOLT AT DRUM CONTROL. Protects motor against overload, low and no voltage. Motor will not automatically restart when power is restored—drum control† has momentary contactors.

No. 7033 THERMAL OVERLOAD UNIT, for 1 or 3 phase. Automatically cuts out to prevent damage to motor from overheating. Has manual reset button. Installed between drum switch and motor.

*Magnetic starter for single phase—price on application.
 †Operated by standard lever on headstock.